

ED-29768-000
SHT 1.1

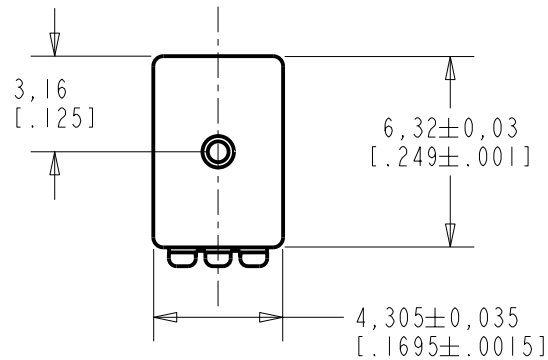

- NOTE:
- 1 A POSITIVE GOING VOLTAGE AT TERMINAL 2, RELATIVE TO THE CENTER TAP TERMINAL, OR A NEGATIVE GOING VOLTAGE AT TERMINAL 1, RELATIVE TO THE CENTER TAP TERMINAL, CAUSES A DECREASE IN PRESSURE AT THE SOUND OUTLET.
 - 2 LOCATED FROM TWO SURFACES FOR CUSTOMER CONVENIENCE. ONLY APPLICABLE FROM ONE SURFACE, NOT TO BE USED TOGETHER. HORIZONTAL LOCATION FOR TERMINAL CENTERED TO ±0,17 [0.007].

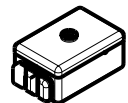
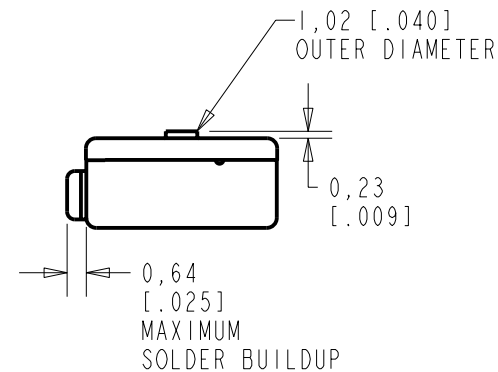
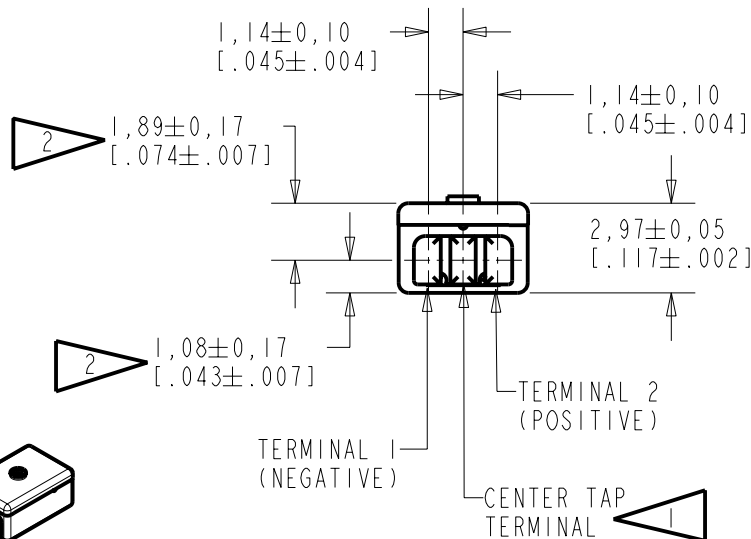

SCALE 2:1

NOMINAL WEIGHT
.31 GRAM

DIMENSIONS IN MILLIMETERS [INCHES]

KNOWLES ELECTRONICS
ITASCA, ILLINOIS U.S.A.

Revision	C.O. #	Implementation Date	RELEASE LEVEL	REVISION
			Released	A
A	CI0103510	12-28-05		
SCALE: 4:1			DR. BY	DATE
DO NOT SCALE DRAWING			CRG	12-28-05
TITLE: RECEIVER			ED-29768-000	CK. BY
OUTLINE DRAWING			SHT 1.1	GJP
			APP. BY	DATE
			GJP	1-2-06

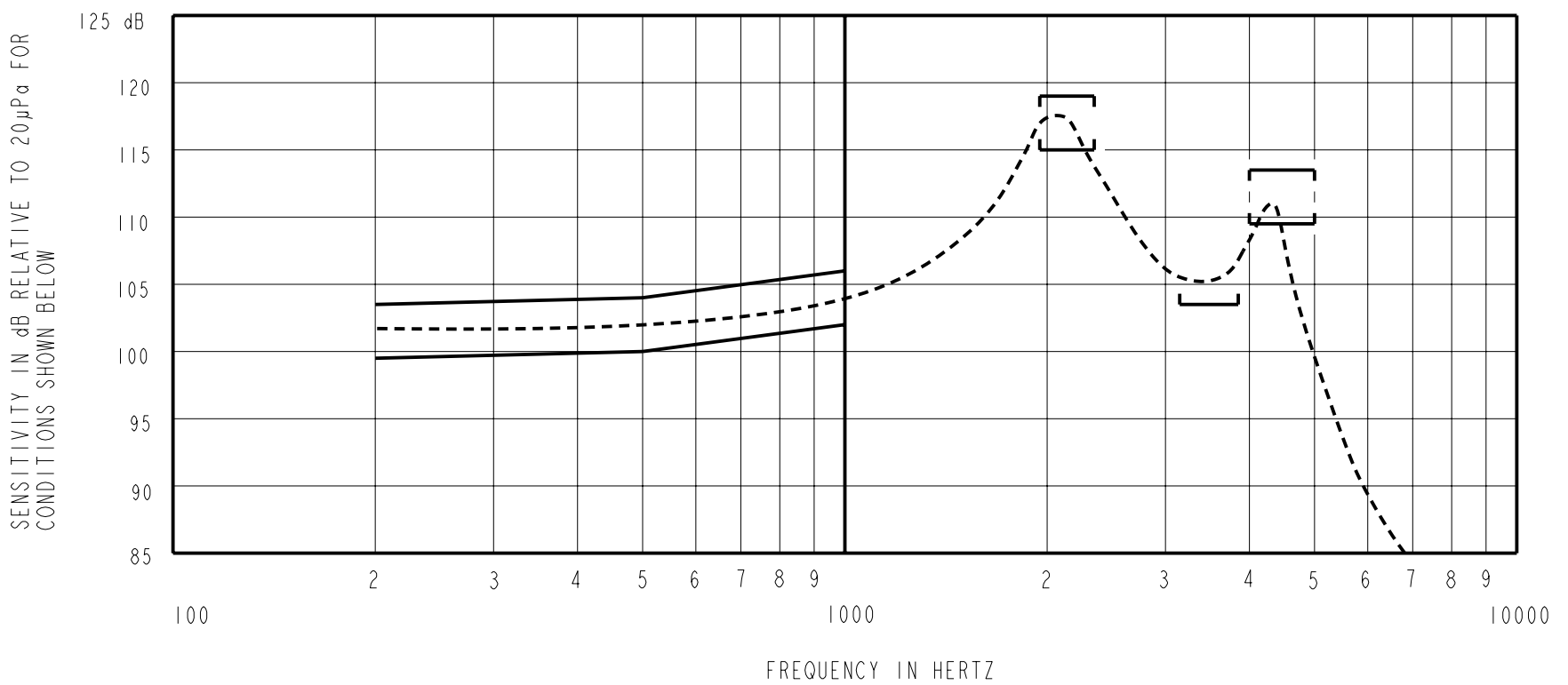

NOTES:

1. MEASUREMENTS MADE USING 10m (.394") X 1mm (.039") ID TUBE CONNECTED TO A SIMULATED ANSI S3.7-1973 TYPE HA-3 COUPLER. (IEC 126).

2. SENSITIVITY

FREQUENCY	MIN.	MAX.
200	99.5	103.5
500	100.0	104.0
1000	102.0	106.0
1950-2350	115.0	119.0
3150-3850	103.5	---
4000-5000	109.5	113.5

- RESPONSE, IMPEDANCE, AND DISTORTION MEASUREMENTS MADE USING THE ELECTRICAL TEST CONDITIONS SHOWN BELOW.
- ELECTRICAL SOURCE IMPEDANCE MUST BE GREATER THAN 20 TIMES 1KHz IMPEDANCE FOR TEST CONDITIONS SHOWN BELOW.
- INDIVIDUAL SPECIFICATIONS.

PORT LOCATION	IMPEDANCE OHMS ±15%		DCR @20°C OHMS ±10%	DISTORTION		ELECTRICAL TEST CONDITIONS	
	1KHz	500Hz		MAX. %	FREQ Hz	AC mA RMS	DC mA
0JM	1450	780	376	5	800	0.50	0.00

Revision	C.O. #	Implementation Date	RELEASE LEVEL	REVISION
A	C10103510	12-28-05	Released	A

WHEN TEST LIMITS ARE USED TO ESTABLISH INCOMING INSPECTION ACCEPTANCE/REJECTION CRITERIA, CORRELATION OF TEST EQUIPMENT WITH KNOWLES IS ALSO REQUIRED FOR ELIMINATION OF EQUIPMENT AND TEST METHOD VARIATION		DR. BY	DATE
TITLE: RECEIVER PERFORMANCE SPECIFICATION		CRG	12-28-05
		GJP	1-2-06
ED-29768-000 SHT 2.1		APP. BY	DATE
		GJP	1-2-06

KNOWLES ELECTRONICS
ITASCA, ILLINOIS U.S.A.