

PIN Silicon Photodiode

OP993, OP999



Features:

- Choice of TO-18 (OP993) or T-1¾ package (OP999)
- Small package style ideal for space-limited applications
- Linear response vs. irradiance
- Fast switching time
- Choice of narrow or wide receiving angle

Description:

Each **OP993** and **OP999** device consists of a PIN silicon photodiode molded in a dark blue injection molded shell package that provides excellent optical and mechanical axis alignment, optical lens surface, control of chip placement and consistency of the outside package dimensions.

OP993 has a TO-18 package style and a *wide* receiving angle that provides excellent on-axis coupling. **OP999** has a T-1¾ package style and a *narrow* receiving angle that provides excellent on-axis coupling.

Both devices are 100% production tested for close correlation with OPTEK GaAIAs emitters.

Please refer to Application Bulletin 210 for additional thermal design information.

Applications:

- Non-contact reflective object sensor
- Assembly line automation
- Machine automation
- Machine safety
- End of travel sensor
- Door sensor

| Ordering Information | | | |
|----------------------|------------|---------------|-------------|
| Part Number | Sensor | Viewing Angle | Lead Length |
| OP993 | Photodiode | 118° | 0.75 min |
| OP999 | Photodiode | 18° | |

OP993



| Pin # | Sensor |
|-------|---------|
| 1 | Cathode |
| 2 | Anode |

OP993

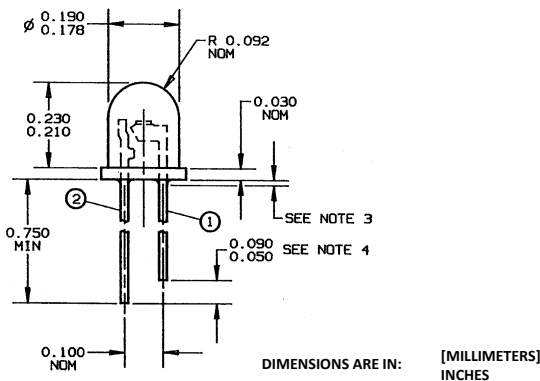

OP999

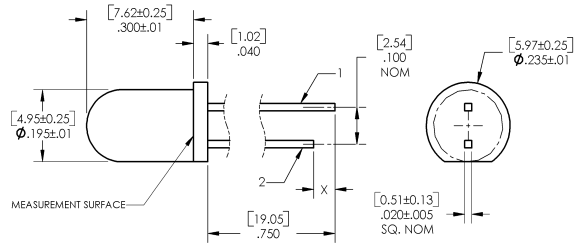

OP999



| Pin # | Sensor |
|-------|---------|
| 1 | Anode |
| 2 | Cathode |

CONTAINS POLYSULFONE

To avoid stress cracking, we suggest using ND Industries' **Vibra-Tite** for thread-locking. **Vibra-Tite** evaporates fast without causing structural failure in OPTEK'S molded plastics.

General Note

TT Electronics reserves the right to make changes in product specification without notice or liability. All information is subject to TT Electronics' own data and is considered accurate at time of going to print.

TT Electronics | OPTEK Technology
 2900 E. Plano Pkwy, Plano, TX 75074 | Ph: +1 972 323 2200
 www.ttelectronics.com | sensors@ttelectronics.com

Electrical Specifications

Absolute Maximum Ratings ($T_A = 25^\circ\text{C}$ unless otherwise noted)

| | |
|---|-------------------|
| Reverse Breakdown Voltage | 60 V |
| Storage & Operating Temperature Range | -40° C to +100° C |
| Lead Soldering Temperature [1/16 inch (1.6 mm) from the case for 5 sec. with soldering iron] ⁽¹⁾ | 260° C |
| Reverse Breakdown Voltage | 60 V |
| Power Dissipation ⁽²⁾ | 100 mW |

Electrical Characteristics ($T_A = 25^\circ\text{C}$ unless otherwise noted)

| SYMBOL | PARAMETER | MIN | TYP | MAX | UNITS | TEST CONDITIONS |
|----------------------|--------------------------------|------|-----|------|---------------|---|
| I_L ⁽³⁾ | Reverse Light Current OP993 | 12.5 | - | 28.5 | μA | $V_R = 5\text{ V}, E_E = 1.7\text{ mW/cm}^2$ $V_R = 5\text{ V}, E_E = 0.25\text{ mW/cm}^2$ |
| | OP999 | 6.5 | - | 15 | | |
| I_D | Reverse Dark Current | - | 1 | 60 | nA | $V_R = 30\text{ V}, E_E = 0$ |
| $V_{(BR)}$ | Reverse Breakdown Voltage | 60 | - | - | V | $I_R = 100\ \mu\text{A}$ |
| V_F | Forward Voltage | - | - | 1.2 | V | $I_F = 1\text{ mA}$ |
| C_T | Total Capacitance | - | 4 | - | pF | $V_R = 20\text{ V}, E_E = 0, f = 1.0\text{ MHz}$ |
| t_r | Rise Time | - | 5 | - | ns | $V_R = 20\text{ V}, \lambda = 850\text{ nm}, R_L = 50\ \Omega$ |
| t_f | Fall Time | - | 5 | - | | |

Notes:

- (1) RMA flux is recommended. Duration can be extended to 10 seconds maximum when flow soldering. A maximum of 20 grams force may be applied to leads when soldering.
- (2) Derate linearly 1.07 mW/° C above 25° C.
- (3) Light source is an unfiltered GaAlAs emitting diode operating at peak emission wavelength of 890 nm and $E_{E(APT)}$ of 1.7 mW/cm² for OP993 and 0.25 mW/cm² for OP999 average within a 0.25" diameter aperture.
- (4) This dimension is held to within $\pm 0.005''$ on the flange edge and may vary up to $\pm 0.020''$ in the area of the leads.

General Note

TT Electronics reserves the right to make changes in product specification without notice or liability. All information is subject to TT Electronics' own data and is considered accurate at time of going to print.

Typical Performance

OP993

Light Current vs Angular Displacement

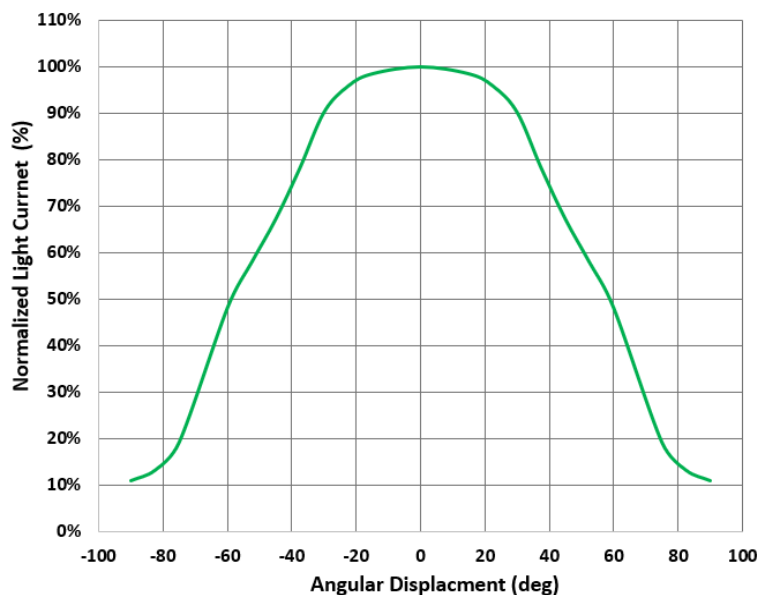

OP999

Light Current vs Angular Displacement

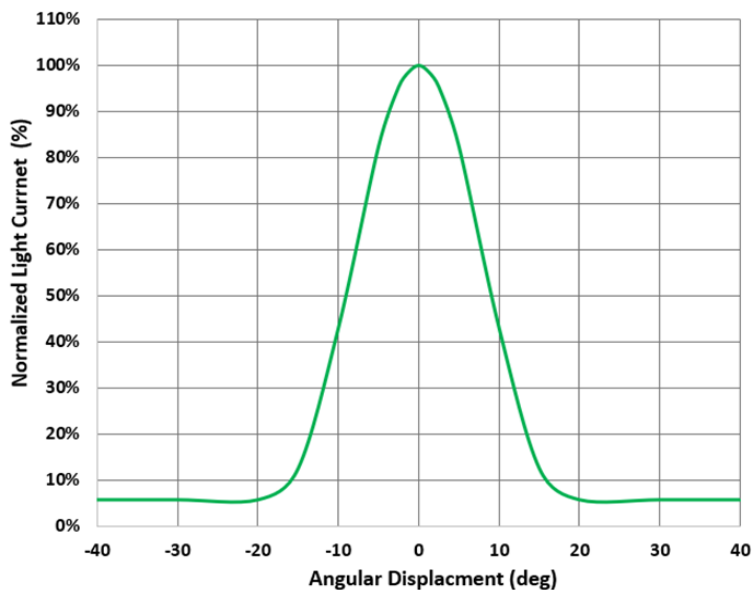

General Note

TT Electronics reserves the right to make changes in product specification without notice or liability. All information is subject to TT Electronics' own data and is considered accurate at time of going to print.

TT Electronics | OPTEK Technology
2900 E. Plano Pkwy, Plano, TX 75074 | Ph: +1 972 323 2200
www.ttelectronics.com | sensors@ttelectronics.com

Typical Performance

OP993 & OP999

Typical Spectral Response

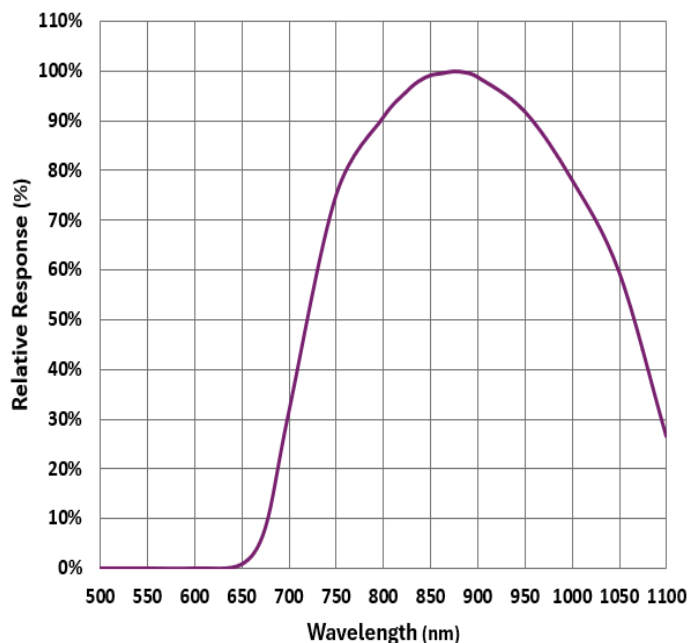

Normalized Light Current vs Temperature

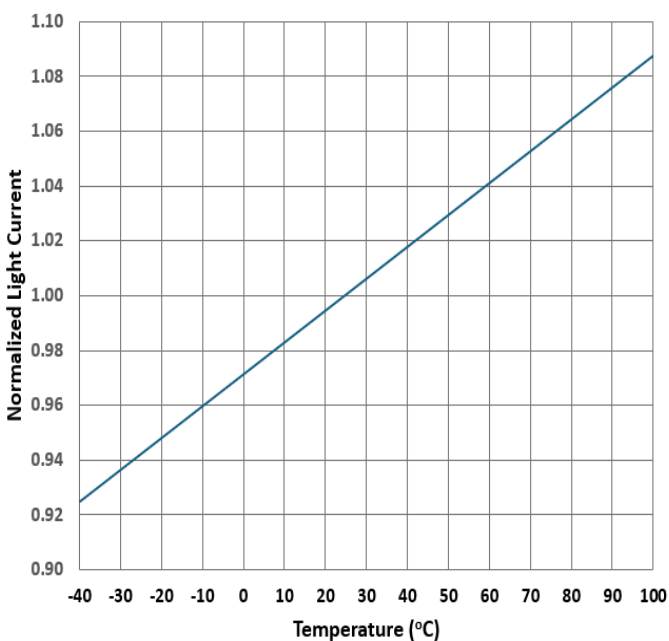

Total Capacitance vs Voltage

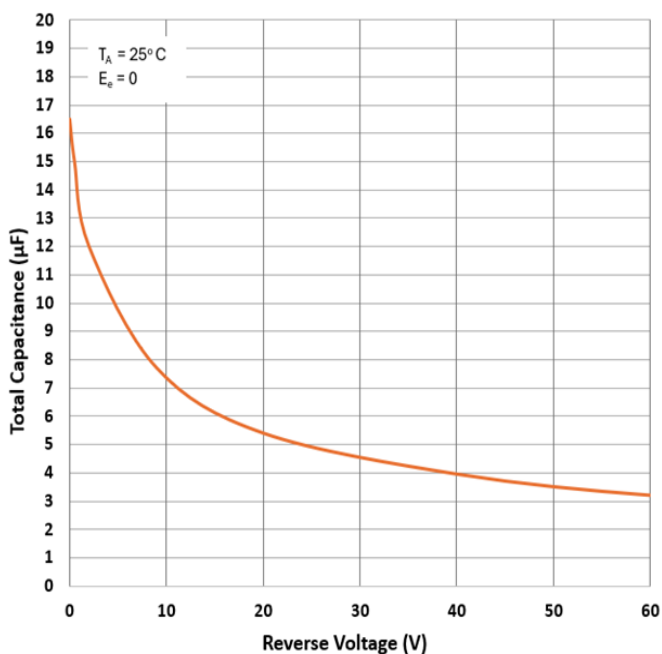

Dark Current vs Temperature

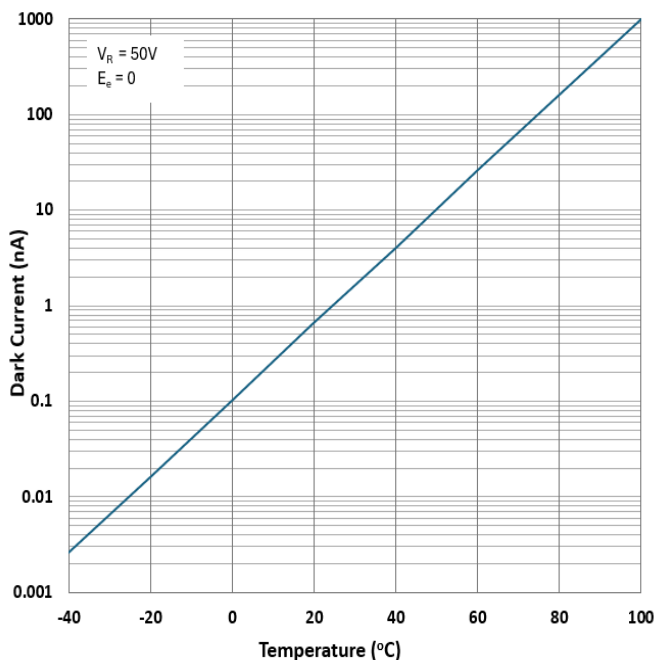

General Note

TT Electronics reserves the right to make changes in product specification without notice or liability. All information is subject to TT Electronics' own data and is considered accurate at time of going to print.