

DRAWING FOR REFERENCE: This is subject to change without notice
08/11/2012

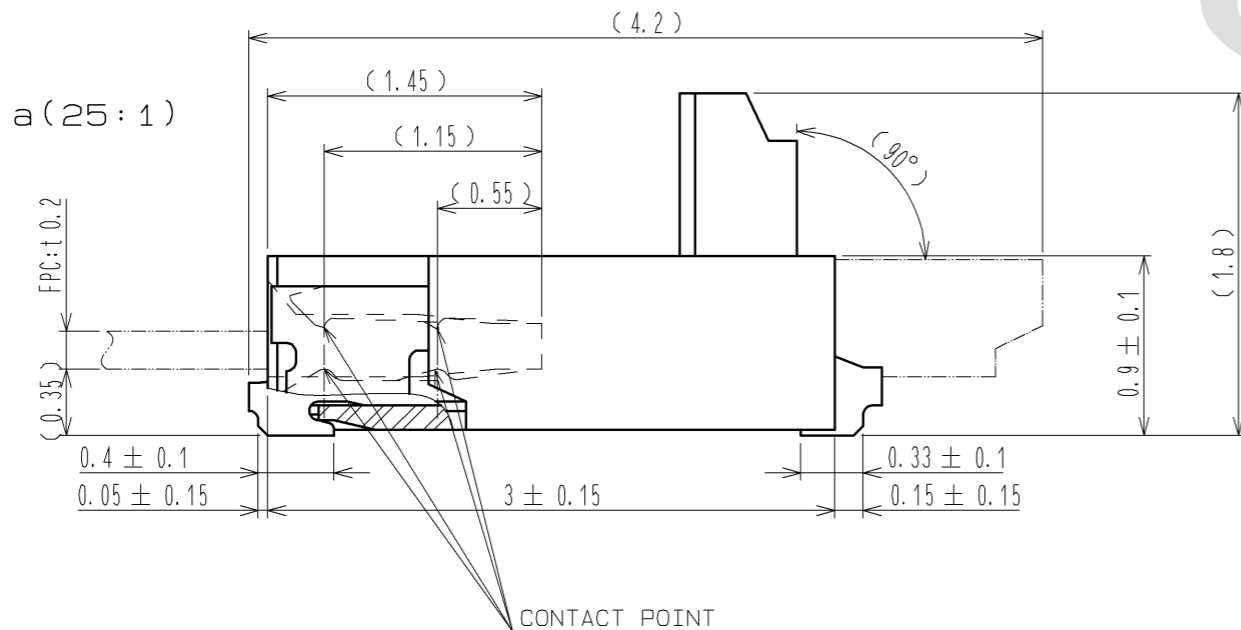

RECOMMENDED PCB MOUNTING PATTERN (SCALE:FREE)
(RECOMMENDED STENCIL THICKNESS: t=0.1)

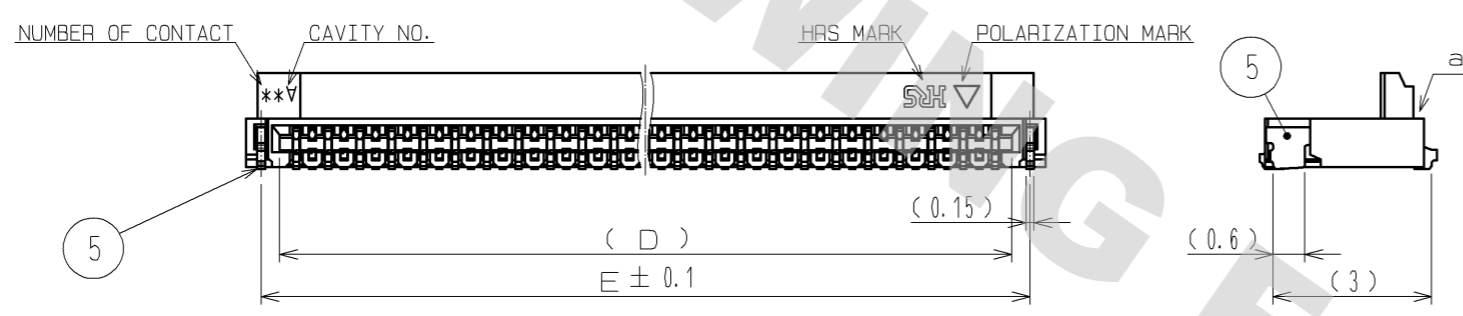
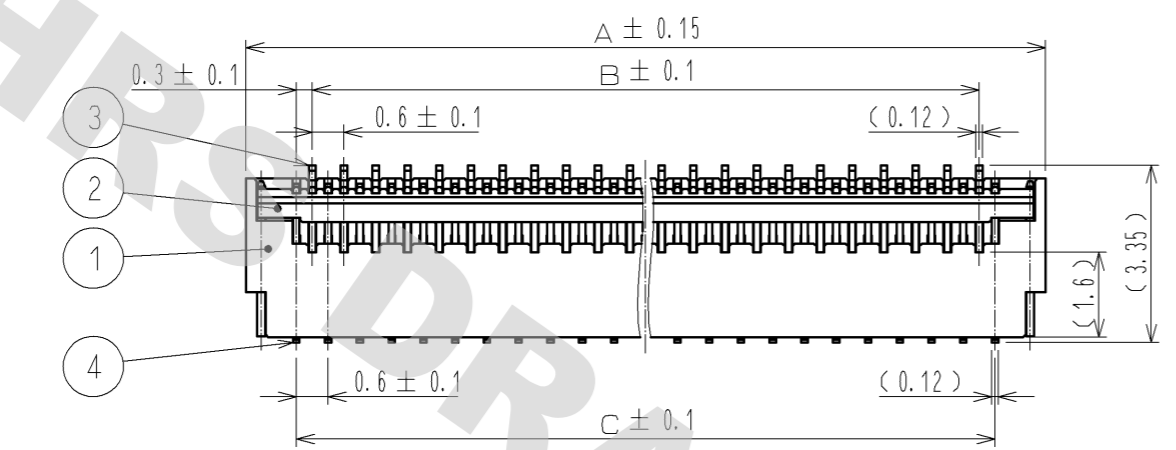
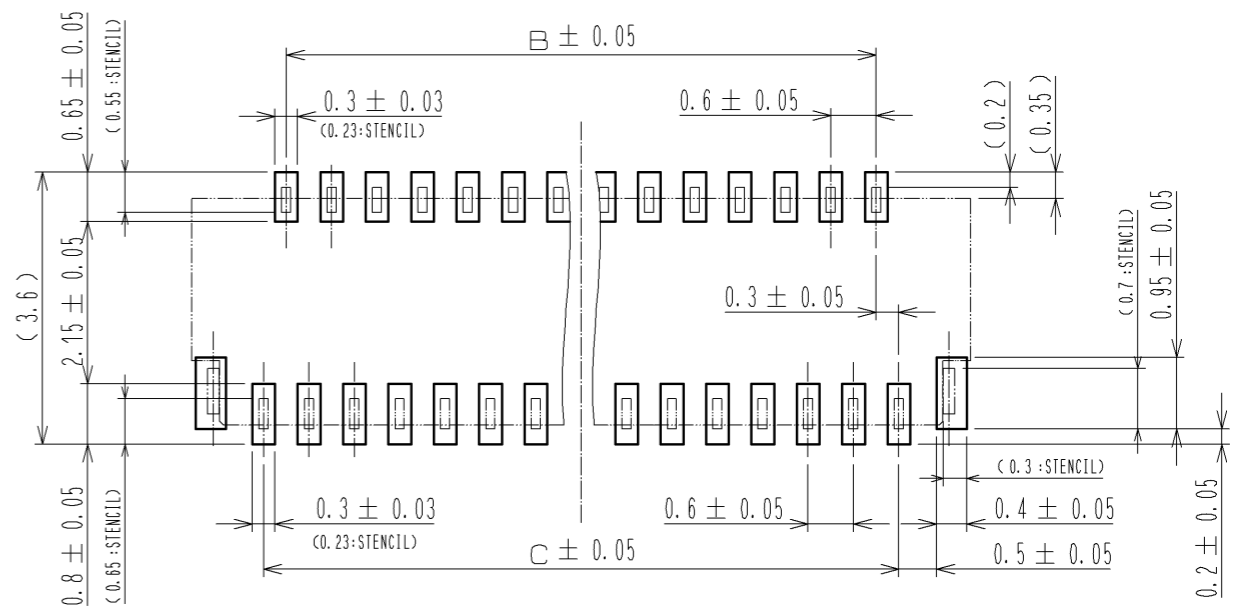

- NOTE
- Lead Co-Planarity including reinforced metal fittings shall be 0.1 MAX.
 - To be delivered with tape and reel packages.
See attached packaging specifications for details.
 - Note that preventive hole for sink mark could be added for improvement.
The quality remains good, even with the dark spots, which could occasionally occur on molded plastic.
 - This product satisfies halogen free requirements defined as 900ppm maximum chlorine, 900ppm maximum bromine, and 1500ppm maximum total of chlorine and bromine.

4	PHOSPHOR BRONZE	(CONTACT AREA, LEAD) GOLD 0.03µm MIN OVER NICKEL 1µm MIN (OTHER) NICKEL PLATING 1µm MIN	10 (CONNECTOR)		
3	PHOSPHOR BRONZE	(CONTACT AREA, LEAD) GOLD 0.03µm MIN OVER NICKEL 1µm MIN (OTHER) NICKEL PLATING 1µm MIN	9 POLYSTYRENE	8 POLYESTER	
2	PA	BLACK UL94V-0	7 POLYSTYRENE	6 PHOSPHOR BRONZE (PLATED MATERIAL)	TIN PLATING (REFLOW FINISHED) 1µm MIN OVER COPPER 0.5µm MIN
1	LCP	GRAY UL94V-0		5 PHOSPHOR BRONZE (PLATED MATERIAL)	TIN PLATING (REFLOW FINISHED) 1µm MIN OVER COPPER 0.5µm MIN
NO.	MATERIAL	FINISH . REMARKS	NO.	MATERIAL	FINISH . REMARKS
UNITS	mm	SCALE	7 : 1	COUNT	△
DESCRIPTION OF REVISIONS		DESIGNED	CHECKED	DATE	
APPROVED : MO. ISHIDA		12.04.11	DRAWING NO. EDC3-338903-02		
CHECKED : FN. TAMURA		12.04.11	PART NO. FH35C-**S-0.3SHW<10>		
DESIGNED : YS. EBI		12.04.10	CODE NO. CL580		
DRAWN : YS. EBI		12.04.10	1/6		

DRAWING FOR REFERENCE: This is subject to change without notice
08/11/2012

PART NUMBER	CODE NUMBER	NUMBER OF CONTACTS	DIMENSION OF CONNECTOR, FPC, PCB MOUNTING PATTERN AND STENCIL						DIMENSION OF DRAWING FOR PACKING					
			A	B	C	D	E	F	G	H	J	K	L	M
FH35C-9S-0.3SHW(10)	CL580-2910-5-10	9	4.3	1.8	2.4	3.03	3.73	3.0	16	—	7.5	4.5	17.4	21.4
FH35C-11S-0.3SHW(10)	CL580-2917-4-10	11	4.9	2.4	3.0	3.63	4.33	3.6	16	—	7.5	5.1	17.4	21.4
FH35C-13S-0.3SHW(10)	—	13	5.5	3.0	3.6	4.23	4.93	4.2	16	—	7.5	5.7	17.4	21.4
FH35C-15S-0.3SHW(10)	CL580-2919-0-10	15	6.1	3.6	4.2	4.83	5.53	4.8	16	—	7.5	6.3	17.4	21.4
FH35C-17S-0.3SHW(10)	CL580-2916-1-10	17	6.7	4.2	4.8	5.43	6.13	5.4	16	—	7.5	6.9	17.4	21.4
FH35C-19S-0.3SHW(10)	CL580-2921-1-10	19	7.3	4.8	5.4	6.03	6.73	6.0	16	—	7.5	7.5	17.4	21.4
FH35C-21S-0.3SHW(10)	CL580-2922-4-10	21	7.9	5.4	6.0	6.63	7.33	6.6	24	—	11.5	8.1	25.4	29.4
FH35C-23S-0.3SHW(10)	CL580-2911-8-10	23	8.5	6.0	6.6	7.23	7.93	7.2	24	—	11.5	8.7	25.4	29.4
FH35C-25S-0.3SHW(10)	CL580-2912-0-10	25	9.1	6.6	7.2	7.83	8.53	7.8	24	—	11.5	9.3	25.4	29.4
FH35C-27S-0.3SHW(10)	CL580-2918-7-10	27	9.7	7.2	7.8	8.43	9.13	8.4	24	—	11.5	9.9	25.4	29.4
FH35C-31S-0.3SHW(10)	CL580-2923-7-10	31	10.9	8.4	9.0	9.63	10.33	9.6	24	—	11.5	11.1	25.4	29.4
FH35C-33S-0.3SHW(10)	CL580-2913-3-10	33	11.5	9.0	9.6	10.23	10.93	10.2	24	—	11.5	11.7	25.4	29.4
FH35C-35S-0.3SHW(10)	—	35	12.1	9.6	10.2	10.83	11.53	10.8	24	—	11.5	12.4	25.4	29.4
FH35C-37S-0.3SHW(10)	CL580-2914-6-10	37	12.7	10.2	10.8	11.43	12.13	11.4	24	—	11.5	12.9	25.4	29.4
FH35C-39S-0.3SHW(10)	CL580-2915-9-10	39	13.3	10.8	11.4	12.03	12.73	12.0	24	—	11.5	13.5	25.4	29.4
FH35C-41S-0.3SHW(10)	CL580-2924-0-10	41	13.9	11.4	12.0	12.63	13.33	12.6	24	—	11.5	14.1	25.4	29.4
FH35C-45S-0.3SHW(10)	CL580-2909-6-10	45	15.1	12.6	13.2	13.83	14.53	13.8	24	—	11.5	15.3	25.4	29.4
FH35C-49S-0.3SHW(10)	—	49	16.3	13.8	14.4	15.03	15.73	15.0	32	28.4	14.2	16.5	33.4	37.4
FH35C-51S-0.3SHW(10)	CL580-2920-9-10	51	16.9	14.4	15.0	15.63	16.33	15.6	32	28.4	14.2	17.1	33.4	37.4

※ CONTACT POSITIONS WITHOUT CODE NUMBERS ARE CURRENTLY UNDER PLANNING.
CONTACT HIROSE FOR DETAILED INFORMATION ABOUT PRODUCT VARIATION.

HRS	DRAWING NO.	EDC3-338903-02	
	PART NO.	FH35C-**S-0.3SHW(10)	
	CODE NO.	CL580	△ 4/6

This connector features small, thin and back flip design, requiring delicate and careful handling. Read through the instructions shown below and handle the connector properly.

[Operation and Precautions]

1. Initial condition

Actuator does not have to be operated before inserting FPC, as the connector is delivered with the actuator opened.

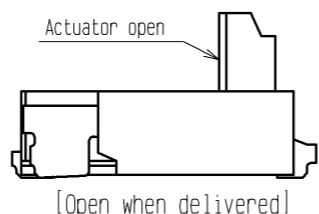

[Prohibited acts]

- Do not close the actuator before inserting FPC. Closing the actuator without FPC could make the contact gap smaller, which could increase the FPC insertion force when FPC is inserted. (Figure:1)
- Do not insert the FPC at a sharp angle as this may cause contact deformation by the FPC touching to contact tips. (Figure:2)

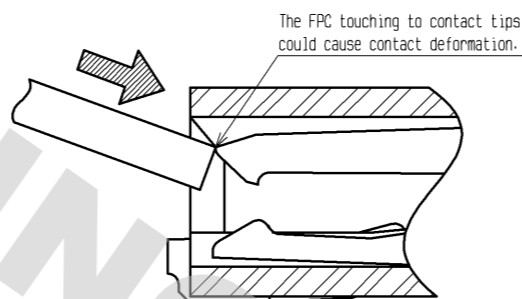
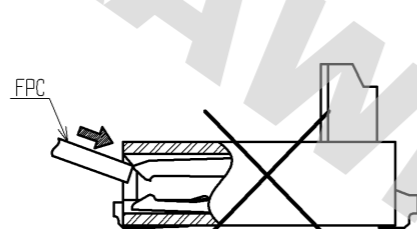
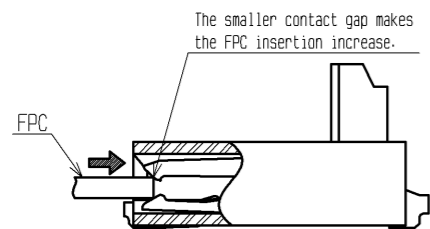
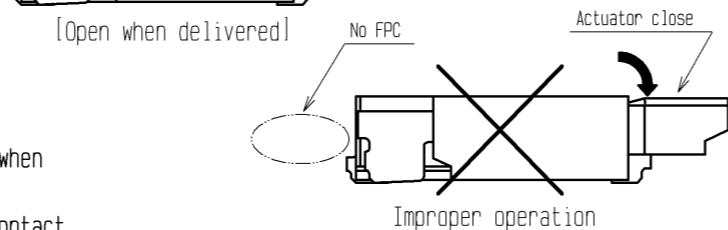

4. How to lock

Apply load to rotate the actuator by 90 degree after inserting the FPC.

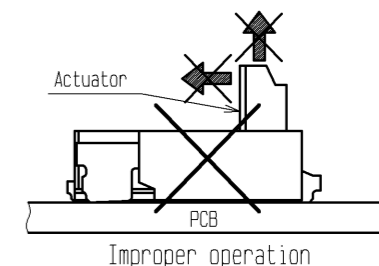
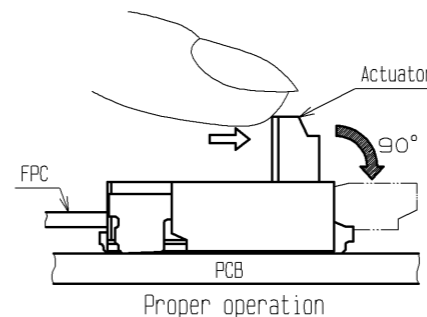

[Caution]

- The actuator rotates around the rotational axis as shown below.
- Do not rotate the actuator to the counter direction. Do not pinch or pick the actuator to lift. Otherwise, it may break.
- Apply load to the mid-point on the actuator to rotate it. Do not apply force to side end of the actuator. Uneven load could twist the actuator and cause half mating.
- Do not apply excess force to the housing during the operation.

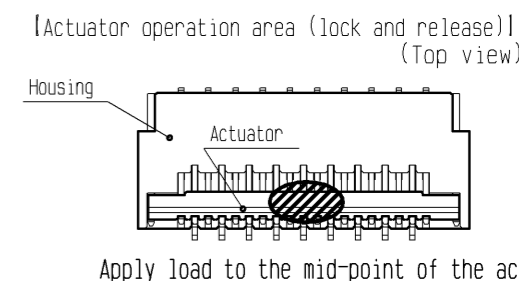
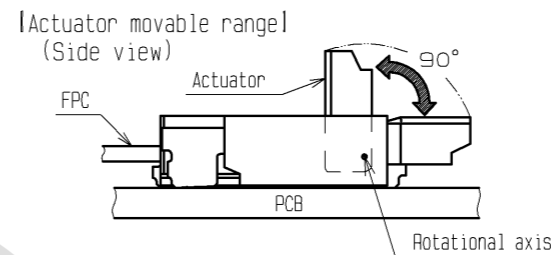

2. How to insert FPC

Insert the FPC into the connector opening horizontally to the board plane. Insert it properly to the very end.

[Caution]

- Insert the FPC with the actuator opened.
- Twisting the FPC to up and down, right and left or an angle could cause contact deformation and contact failure.

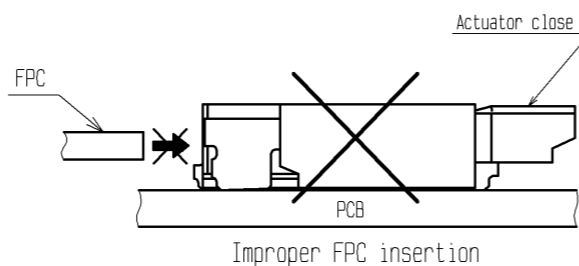
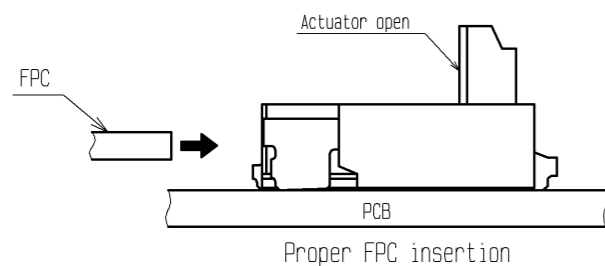

5. How to remove FPC (How to unlock)

Slowly flip up the actuator to release the lock and remove the FPC.

[Caution]

- The actuator is opened up to the movable limit, 90 degree. Do not open the actuator beyond the specified degree or apply excess force to the actuator.
- To open the actuator, operate at the mid-point of the actuator. Do not lift up the side end of the actuator, or it may twist the actuator and cause breakage.
- Please note that the connector is back flip style connector, and the opening for FPC insertion and the actuator face the opposite direction. Do not try to lift the actuator at the FPC insertion opening side.
- Do not press down the actuator toward connector when operating. Otherwise it could deform the contact.

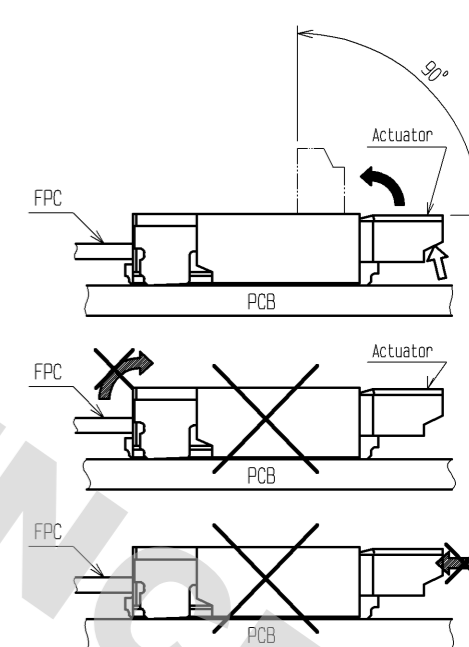

3. FPC insertion check (for using contacts on the top, for FPC pattern only applicable to FH35)

Improper assembly modes are prevented by visual check, comparing positions of housing opening end line and FPC pattern line.

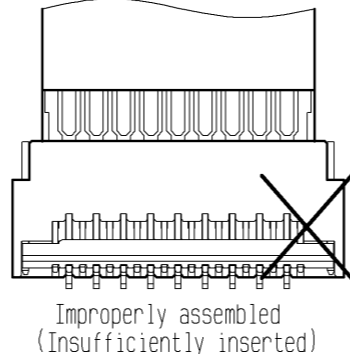
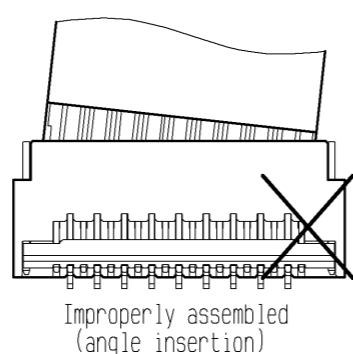
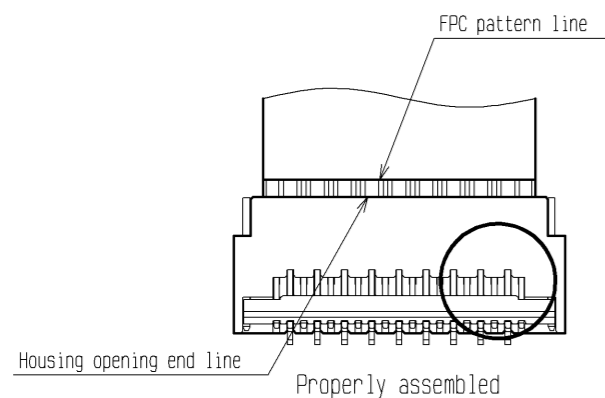

HRS	DRAWING NO.	EDC3-338903-02
	PART NO.	FH35C-**S-0.3SHW<10>
	CODE NO.	CL580
		5/6

DRAWING FOR REFERENCE: This is subject to change without notice 08/11/2012

This connector features small, thin and back flip design, requiring delicate and careful handling. Read through the instructions shown below and handle the connector properly.

6. How to FPC routing (for using contacts on the bottom)

Do not apply load to FPC when locating FPC.
It leads to the disconnection break or damage of FPC.
In addition, there is possibility to make a conduction failure if applying load to connector.

[Prohibited acts]

- Please design FPC routing so that FPC stiffener will not interfere with cover case.
- When fixing FPC, please do not fix FPC at a position where stress will be put on connector in pulling/insertion/sideways direction.

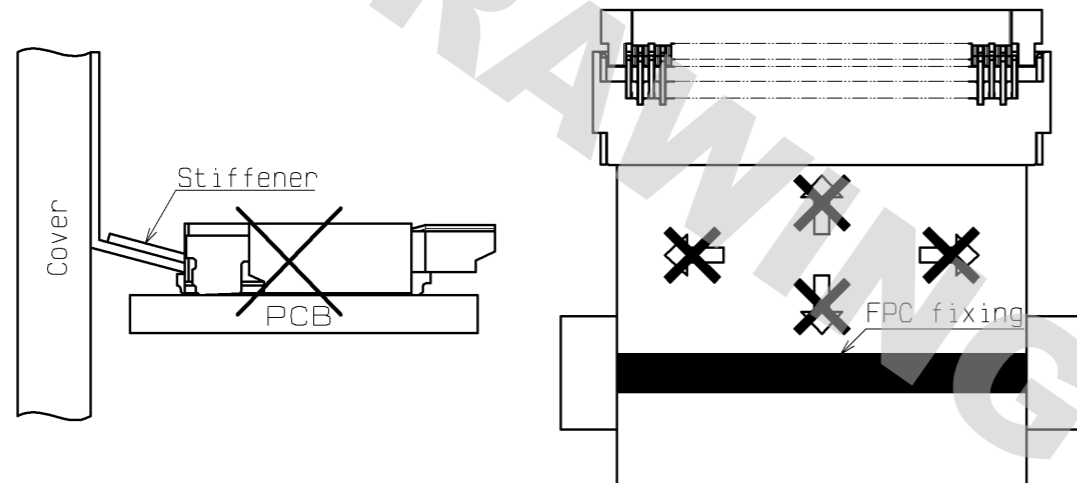

- Please consider not to put extreme pulling force to vertical direction.
- Please do not place any mounting items under stiffener which would touch FPC.

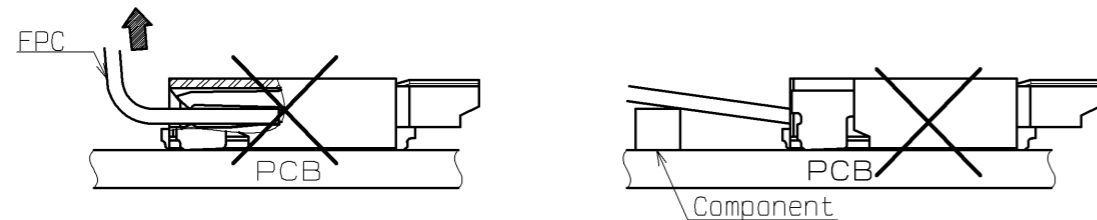

[Precautions for design]

1. During FPC wiring, ensure that stress is not applied directly to the connector. Do not bend the FPC excessively near the connector during use, or it may cause contact failure or FPC breakage. Stabilizing the FPC is recommended.
2. Keep a sufficient FPC insertion space in the stage of the layout in order to avoid incorrect FPC insertion. Appropriate FPC length and component layout are recommended for assembly ease. Too short FPC length makes assembly difficult.
3. Follow the recommended PCB layout, FPC design and the metal mask opening design.
4. Make adjustments with the FPC manufacturer for FPC bending performance and wire breakage.
5. Keep spaces for the actuator movement and its operation for PCB design and component layout.

[Instructions for mounting on the board]

- ◆Warp of board
Minimize warp of the board as much as possible.
Lead co-planarity including reinforced metal fittings is 0.1 mm or less.
Too much warp of the board may result in a soldering failure.
- ◆Load to connector
Do not apply mechanical stress to the connector before mounting on the board.
Otherwise, the connector may be broken.
Do not insert the FPC or operate the connector before mounting.
- ◆Load to board
-Splitting a large board into several pieces
-Screwing the board
Avoid the handling described above so that no force is applied on the board during the assembly process.
Otherwise, the connector may become defective.
- ◆Reflow temperature profile
Apply reflow temperature profile within the specified conditions.
In individual applications, the actual temperature may vary, depending on solder paste type, volume/thickness and board size/thickness.
Consult your solder paste and equipment manufacturer for specific recommendations.
- ◆Amount of bend of board
The bend of a 100-mm wide board should be 1 mm or less as shown below.
The bend of board could apply stress on the connector and it may become defective.

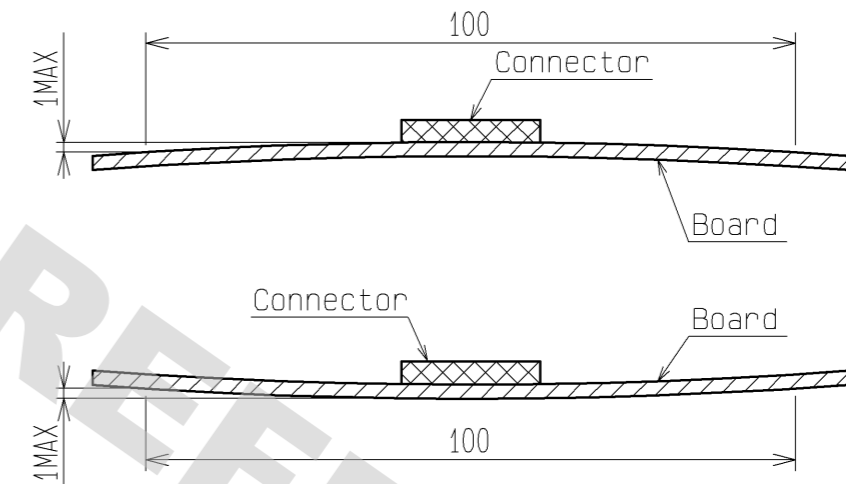

[Other instructions]

- ◆Instructions on manual soldering
Follow the instructions shown below when soldering the connector manually during repair work, etc.

 1. Do not perform manual soldering with the FPC inserted into the connector.
 2. Do not heat the connector excessively. Be very careful not to let the soldering iron contact any parts other than connector leads. Otherwise, the connector may be deformed or melt.
 3. Do not apply excessive solder (or flux).
If excessive solder (or flux) is applied on the terminals, solder or flux may adhere to the contacts or rotating parts of the actuator, resulting in poor contact or a rotation failure of the actuator. Supplying excessive solder to the metal fittings may hinder actuator rotation, resulting in breakage of the connector.

HRS

図番:	EDC3-338903-02
製品名:	FH35C-**S-0.3SHW(10)
製品コード:	CL580

△ 6/6