

Mar.1.2022 Copyright 2022 HIROSE ELECTRIC CO., LTD. All Rights Reserved.
 In case of consideration for using Automotive equipment / device which demand high reliability, kindly contact our sales window correspondents.

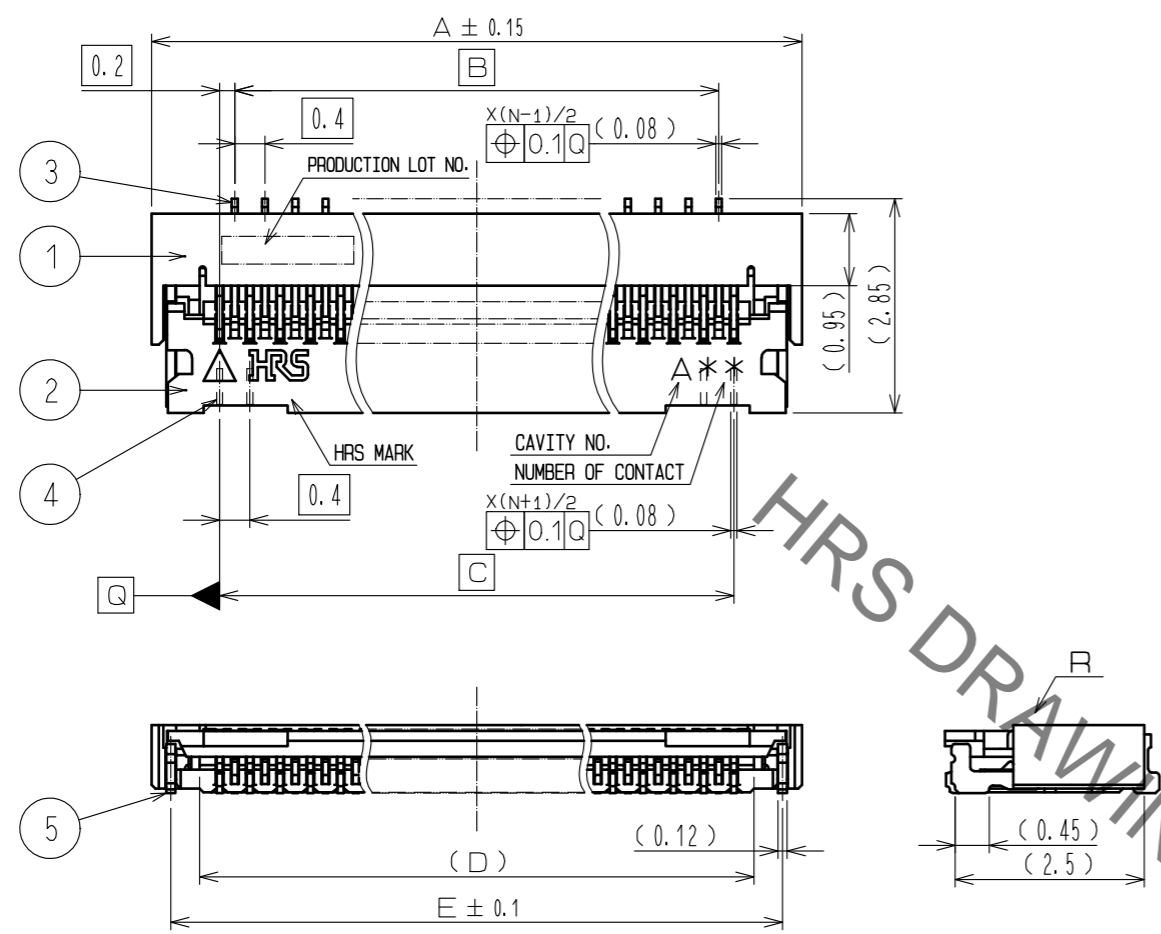

R (30 : 1)

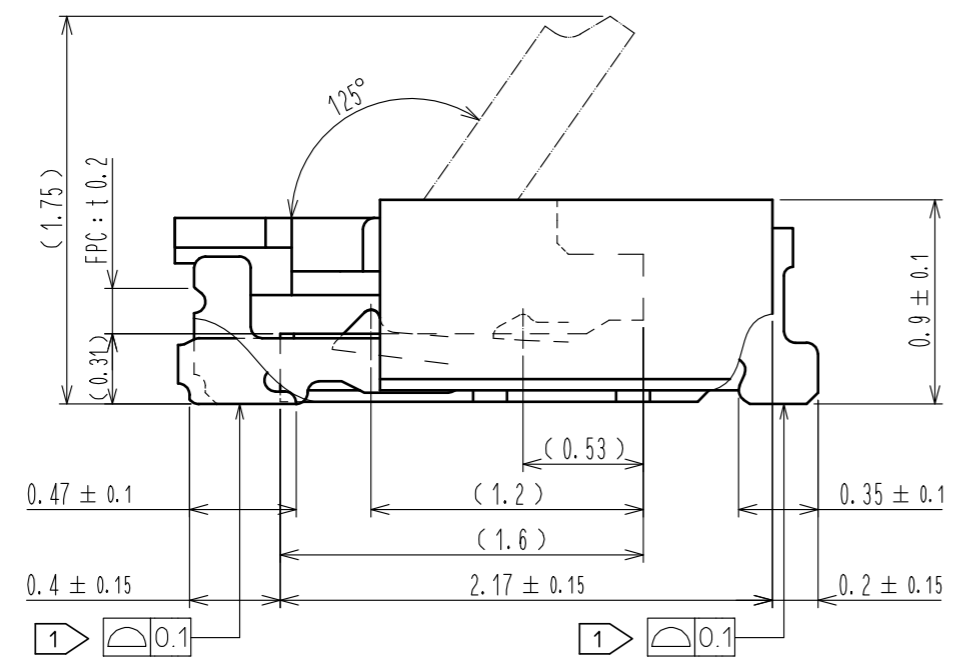

RECOMMENDED LAND PATTERN

(NO SCALE)
 (RECOMMENDED METAL MASK THICKNESS : $t \pm 0.1$)

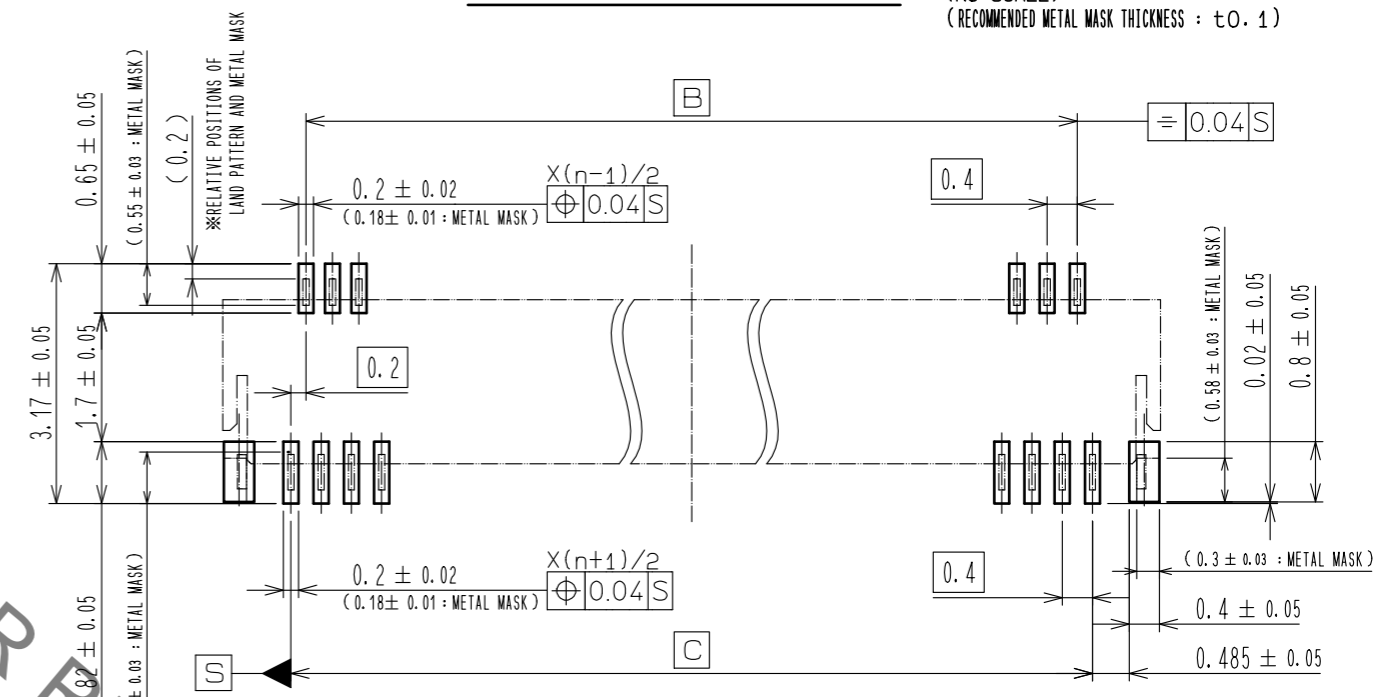

<CONNECTOR DIMENSIONS AND RECOMMENDED LAND PATTERN>

NO.	MATERIAL	FINISH	REMARKS	NO.	MATERIAL	FINISH	REMARKS
4	PHOSPHOR BRONZE	(CONTACT AREA, LEAD) GOLD 0.05μm MIN OVER NICKEL 1μm MIN. (OTHER) NICKEL PLATING 1μm MIN.		9	(CONNECTOR)		
3	PHOSPHOR BRONZE	(CONTACT AREA, LEAD) GOLD 0.05μm MIN OVER NICKEL 1μm MIN. (OTHER) NICKEL PLATING 1μm MIN.		8	POLYSTYRENE		
2	PA	DEEP BROWN UL94V-0		7	POLYESTER		
1	LCP	BEIGE UL94V-0		6	POLYSTYRENE		
				5	PHOSPHOR BRONZE (PLATED MATERIAL)	TIN PLATING(REFLOW FINISHED) 1μm MIN OVER COPPER 0.5μm MIN	

- NOTE 1 LEAD CO-PLANARITY INCLUDING REINFORCED METAL FITTINGS SHALL BE 0.1 MAX.
 2 TO BE DELIVERED WITH TAPE AND REEL PACKAGES.
 3 NOTE THAT PREVENTIVE HOLE FOR SINK MARK COULD BE ADDED FOR IMPROVEMENT. THE QUALITY REMAINS GOOD. EVEN WITH THE DARK SPOTS, WHICH COULD OCCASIONALLY OCCUR MOLDED PLASTICS.

UNITS mm		SCALE 10 : 1	COUNT 2	DESCRIPTION OF REVISIONS DIS-F-00001350	DESIGNED KN. KOBAYASHI	CHECKED YH. MICHIDA	DATE 16.06.06
APPROVED : RI. TAKAYASU 10.04.13				DRAWING NO. EDC-159838-00-01			
CHECKED : FN. TAMURA 10.04.13				PART NO. FH43B-**-S-0.2SHW(10)			
DESIGNED : HS. HIRAHARA 10.04.13				CODE NO. CL580			
DRAWN : HS. HIRAHARA 10.04.13							

Mar.1.2022 Copyright 2022 HIROSE ELECTRIC CO., LTD. All Rights Reserved.
In case of consideration for using Automotive equipment / device which demand high reliability, kindly contact our sales window correspondents.

RECOMMENDED FPC (NO SCALE)

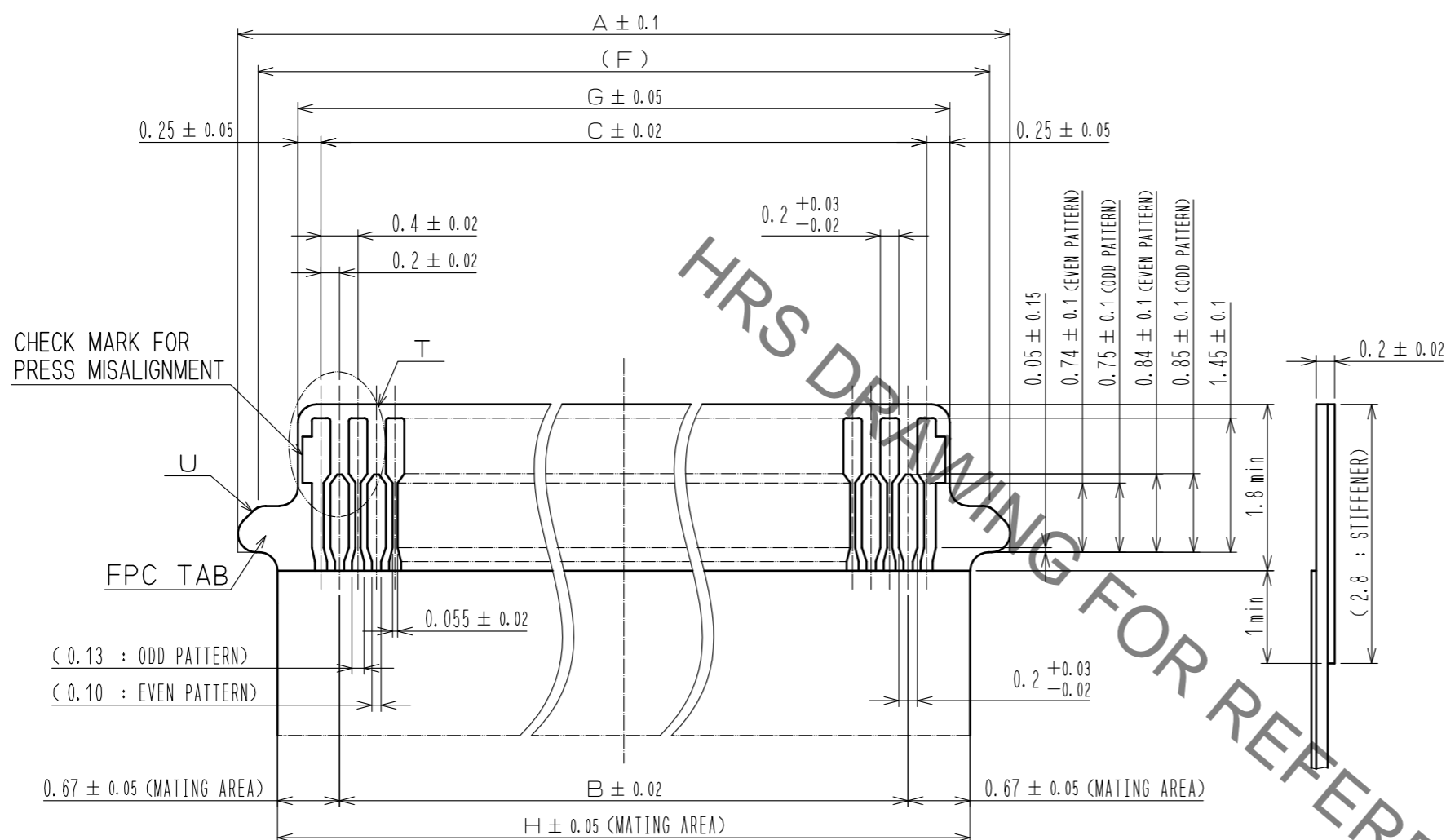

T (30 : 1)

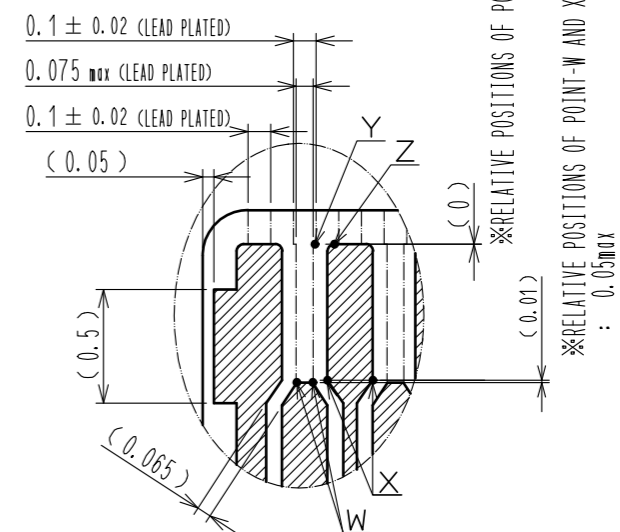

U (20 : 1)

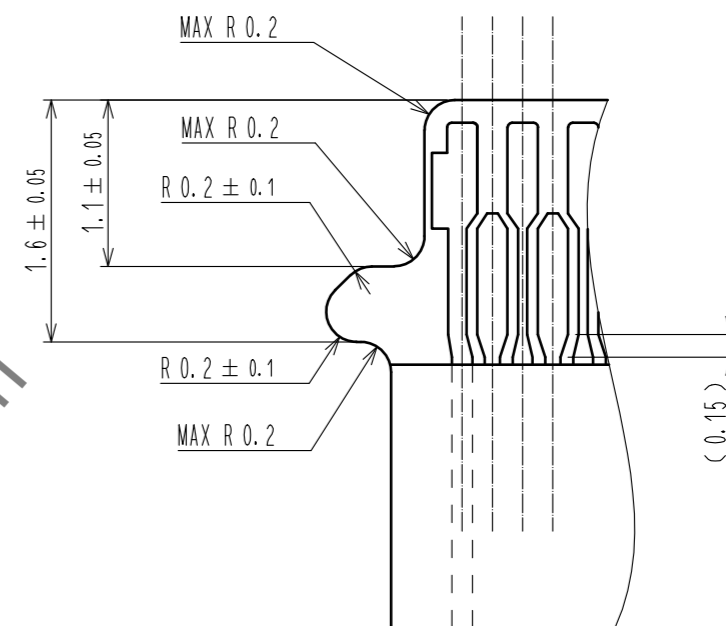

FPC CONSTRUCTION Recommended Specifications

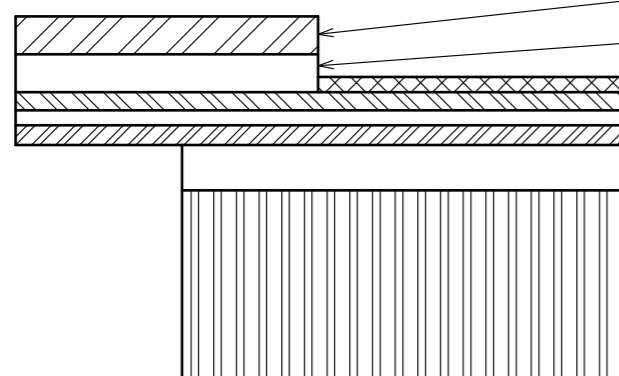

MATERIAL NAME	MATERIAL	THICKNESS(μm)
COVERING FILM LAYER	POLYIMIDE 1 mil	25
COVER ADHESIVE		25
SURFACE TREATMENT	1μm TO 6μm NICKEL UNDERPLATED 0.2μm GOLD PLATED.	(4)
COPPER FOIL	Cu 1/3 oz	12
BASE ADHESIVE	HEAT-HARDENED ADHESIVE	10
BASE FILM	POLYIMIDE 1/2 mil	13
REINFORCEMENT MATERIAL ADHESIVE	HEAT-HARDENED ADHESIVE	30
STIFFENER	POLYIMIDE 5 mil	125

<RECOMMENDED FPC>

HRS	DRAWING NO.	EDC-159838-00-01
	PART NO.	FH43B-**S-0.2SHW<10>
	CODE NO.	CL580
		2/7

Mar.1.2022 Copyright 2022 HIROSE ELECTRIC CO., LTD. All Rights Reserved.
 In case of consideration for using Automotive equipment / device which demand high reliability, kindly contact our sales window correspondents.

EMBOSSED CARRIER TAPE DIMENSION (2:1)

REEL DIMENSION (NO SCALE)

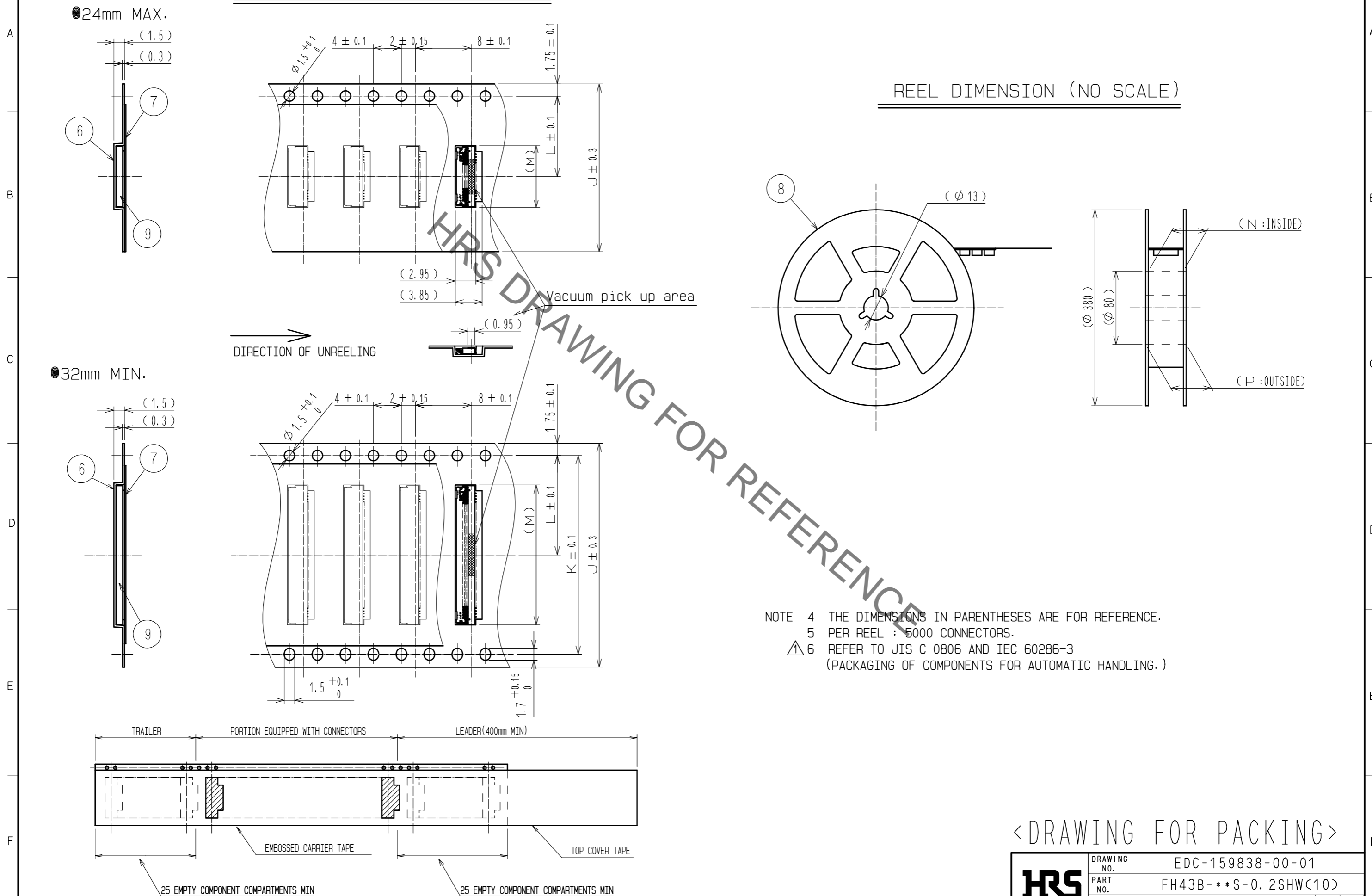

- NOTE 4 THE DIMENSIONS IN PARENTHESES ARE FOR REFERENCE.
 5 PER REEL : 5000 CONNECTORS.
 △ 6 REFER TO JIS C 0806 AND IEC 60286-3
 (PACKAGING OF COMPONENTS FOR AUTOMATIC HANDLING.)

<DRAWING FOR PACKING>

HRS	DRAWING NO.	EDC-159838-00-01
	PART NO.	FH43B-**S-0.2SHW<10>
	CODE NO.	CL580
		△ 3/7

Mar.1.2022 Copyright 2022 HIROSE ELECTRIC CO., LTD. All Rights Reserved.
In case of consideration for using Automotive equipment / device which demand high reliability, kindly contact our sales window correspondents.



PART NUMBER	CODE NUMBER	NUMBER OF CONTACT	DIMENSION OF CONNECTOR, FPC, LAND PATTERN AND METAL MASK									DIMENSION OF DRAWING FOR PACKING					
			A	B	C	D	E	F	G	H	J	K	L	M	N	P	
FH43B-21S-0.2SHW(10)	CL0580-2810-0-10	21	5.8	3.6	4	4.53	5.29	5.3	4.5	4.94	16	-	7.5	6	17.4	21.4	
FH43B-25S-0.2SHW(10)	CL0580-2804-8-10	25	6.6	4.4	4.8	5.33	6.09	6.1	5.3	5.74	16	-	7.5	6.6	17.4	21.4	
FH43B-29S-0.2SHW(10)	CL0580-2811-3-10	29	7.4	5.2	5.6	6.13	6.89	6.9	6.1	6.54	16	-	7.5	7.4	17.4	21.4	
FH43B-31S-0.2SHW(10)	CL0580-2808-9-10	31	7.8	5.6	6	6.53	7.29	7.3	6.5	6.94	24	-	11.5	8	25.4	29.4	
FH43B-35S-0.2SHW(10)	CL0580-2803-5-10	35	8.6	6.4	6.8	7.33	8.09	8.1	7.3	7.74	24	-	11.5	8.8	25.4	29.4	
FH43B-41S-0.2SHW(10)	CL0580-2809-1-10	41	9.8	7.6	8	8.53	9.29	9.3	8.5	8.94	24	-	11.5	10	25.4	29.4	
FH43B-45S-0.2SHW(10)	CL0580-2812-6-10	45	10.6	8.4	8.8	9.33	10.09	10.1	9.3	9.74	24	-	11.5	12	25.4	29.4	
FH43B-51S-0.2SHW(10)	CL0580-2606-3-10	51	11.8	9.6	10	10.53	11.29	11.3	10.5	10.94	24	-	11.5	12	25.4	29.4	
FH43B-61S-0.2SHW(10)	CL0580-2805-0-10	61	13.8	11.6	12	12.53	13.29	13.3	12.5	12.94	24	-	11.5	14	25.4	29.4	
FH43B-71S-0.2SHW(10)	CL0580-2807-6-10	71	15.8	13.6	14	14.53	15.29	15.3	14.5	14.94	24	-	11.5	16	25.4	29.4	

* CONTACT POSITIONS WITHOUT CODE NUMBERS ARE CURRENTLY UNDER PLANNING.
CONTACT HIROSE FOR DETAILED INFORMATION ABOUT PRODUCT VARIATION.

HRS	DRAWING NO.	EDC-159838-00-01
	PART NO.	FH43B-**S-0.2SHW(10)
	CODE NO.	CL580

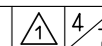

Mar.1.2022 Copyright 2022 HIROSE ELECTRIC CO., LTD. All Rights Reserved.
In case of consideration for using Automotive equipment / device which demand high reliability, kindly contact our sales window correspondents.

This connector is small and thin and requires delicate and careful handling.
Read through the instructions shown below and handle the connector properly.
Each values indicating here are for reference and may differ from standard value.

[INSTRUCTIONS FOR MOUNTING ON THE BOARD]

◆Warp of Board

Minimize warp of the board as much as possible.
Lead co-planarity including reinforced metal fittings is 0.1 mm or less.
Too much warp of the board may result in a soldering failure.

◆Load to Connector

Do not apply a force of 0.5 N or more to the connector before mounting it on the board.
Otherwise, the connector may be broken.
Do not insert the FPC or operate the connector before mounting it.

◆Load to Board

·Splitting a large board into several pieces
·Screwing the board
Avoid the handling described above so that no force is exerted on the board during the assembly process.
Otherwise, the connector may become defective.

◆Amount of Warp

The warp of a 100mm wide board should be 0.5 mm or less.
The warp of board suffers stress on connector and the connector may become defective.

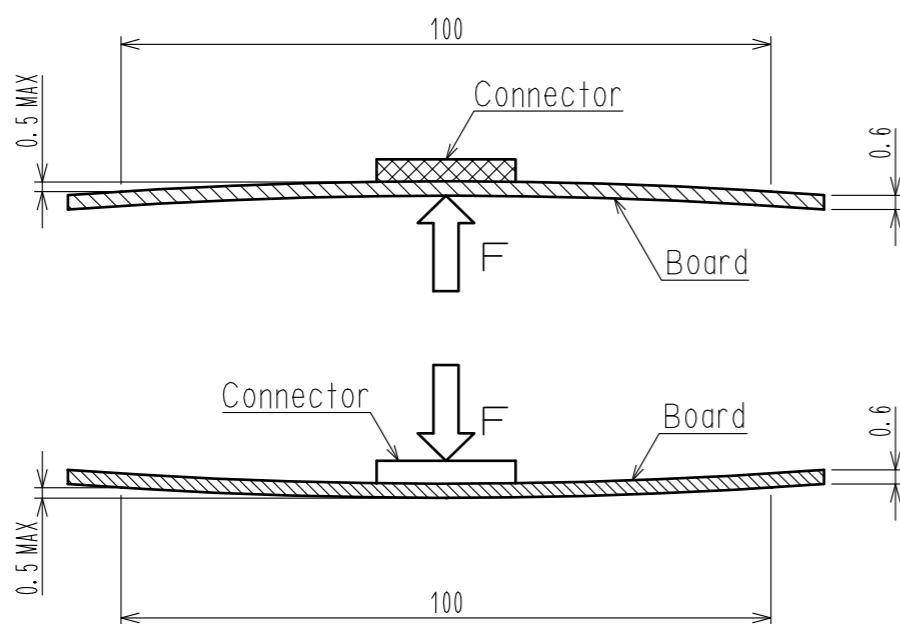

[INSTRUCTIONS ON INSERTING FPC AND CONNECTION]

◆ Use of the actuator

1. Be very careful not to apply excessive force when releasing the actuator in the initial position (with no FPC inserted).
If you use your nail or finger as shown below, the terminals may be deformed.

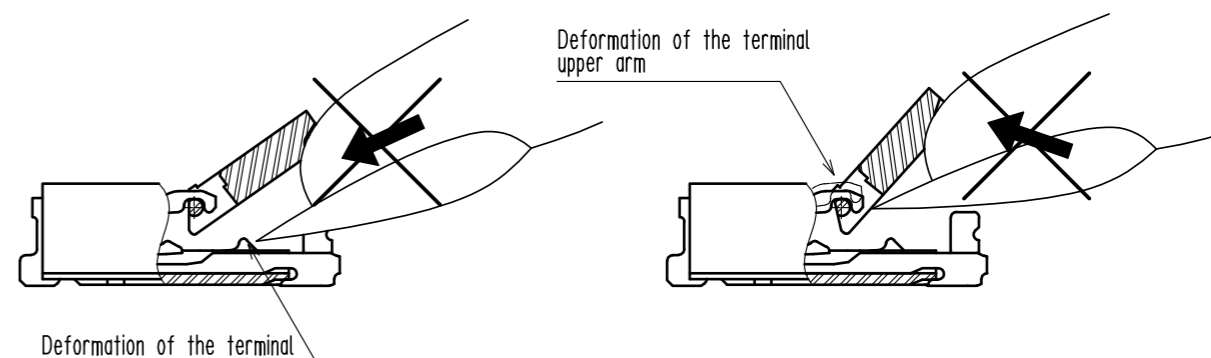

Example 1

Example 2

2. The actuator rotates around the rotational axis as shown below.
Rotate the actuator.

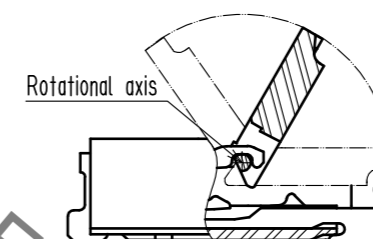

3. The actuator will not open more than 125°.
Do not apply any force backward beyond this point.
Otherwise, the actuator may come off or break.

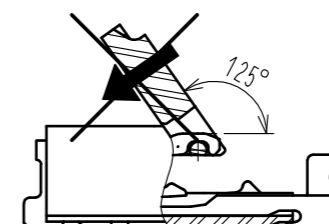

<INSTRUCTION MANUAL 1>

HRS	DRAWING NO.	EDC-159838-00-01
	PART NO.	FH43B-**S-0.2SHWC(10)
	CODE NO.	CL580
		5/7

Mar.1.2022 Copyright 2022 HIROSE ELECTRIC CO., LTD. All Rights Reserved.
In case of consideration for using Automotive equipment / device which demand high reliability, kindly contact our sales window correspondents.

4. Move the actuator at approximately the center.
5. Do not pinch or pick the actuator to lift it as shown below. Otherwise, it may break.
(Do not carry out any operation other than rotating the actuator as shown in 2 above.)

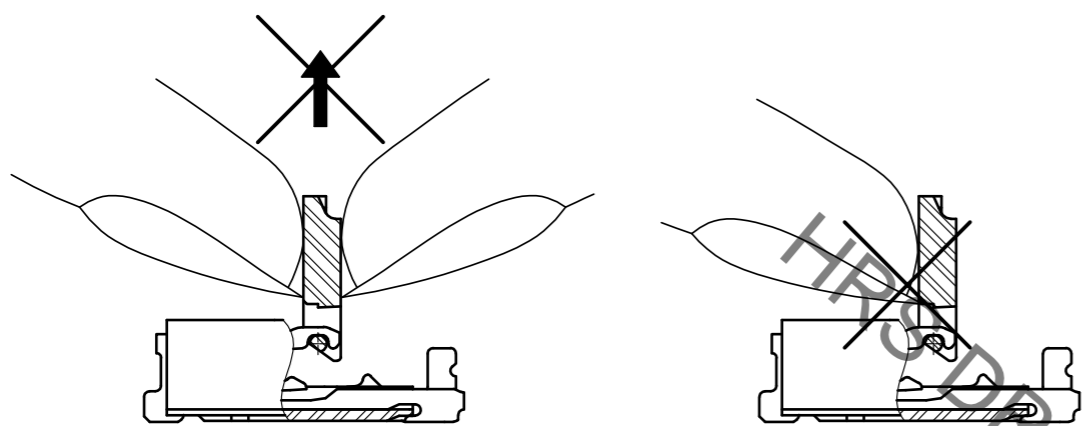

◆Direction of Contacts

This connector has contacts on the bottom. Thus, insert it with the exposed conductors face down.

◆Inserting the FPC

1. Insert the FPC by about 15 degrees along the surface and at a right angle to the connector.
Insert it properly to the very end.
If the FPC is inserted at a slant (incorrectly),
the conductors may short-circuit due to pitch shift or the edge of the FPC may catch in the terminals,
resulting in deformation of the terminals.

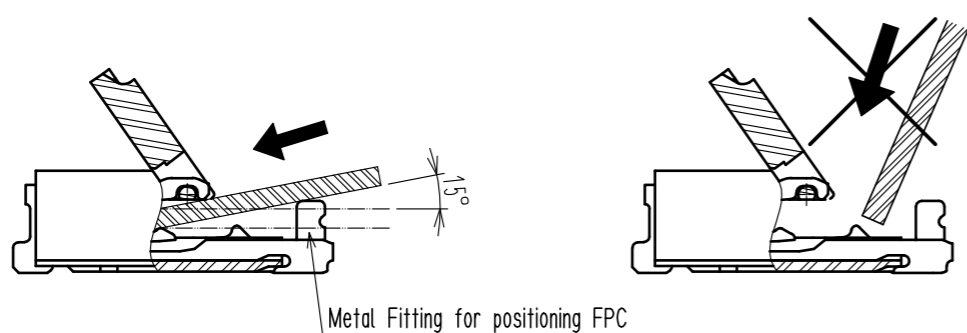

2. Do not insert the FPC diagonally from above.
If the FPC is inserted at a slant (incorrectly) as shown below in the FPC insertion process,
the FPC may bend and patterns may break or the FPC may not insert completely,
resulting in improper conduction.

※Keep a sufficient FPC insertion space in the stage of the layout in order to avoid incorrect FPC insertion.
Besides, it is not difficult to insert FPC correctly all the way to the end.
Design the proper layout of parts.

※Make adjustments with the FPC manufacturer for FPC bending performance and wire breakage.

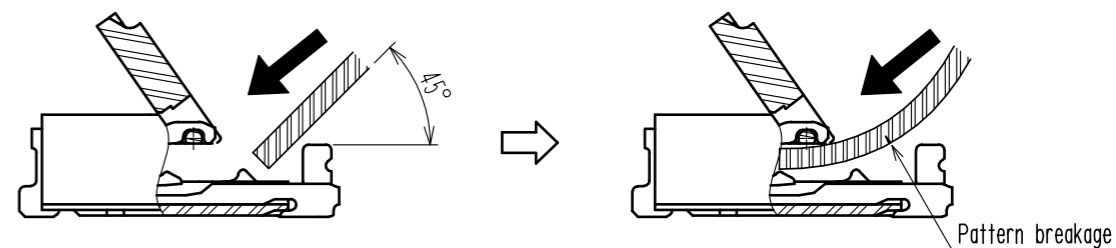

3. Do not rotate the actuator when FPC TAB is on Metal Fittings.
Make sure the position of FPC TAB and Metal Fittings before rotate the actuator.

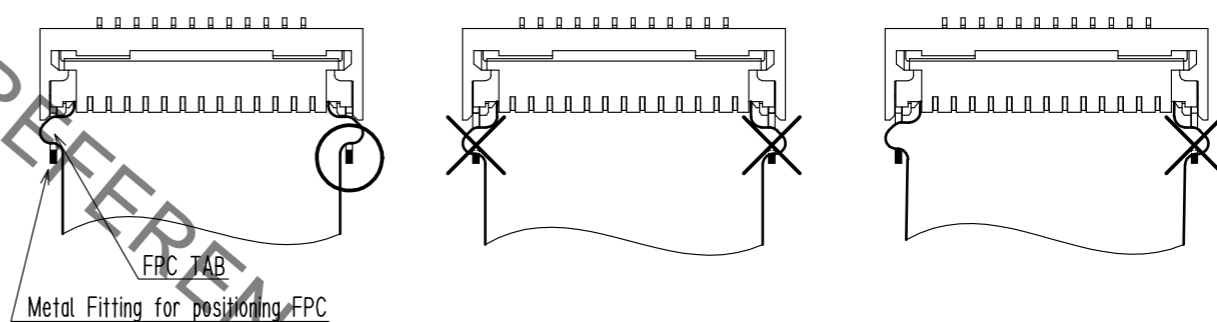

◆Checking the Locking Condition

In the locked condition, make sure that the actuator is horizontal on the board surface.
Do not apply excessive force to it near the 0° position of the actuator.
Otherwise, the terminals may be deformed. (Allowable force: 1 N or less)

<INSTRUCTION MANUAL 2>

HRS	DRAWING NO.	EDC-159838-00-01
	PART NO.	FH43B-**S-0.2SHW<10>
	CODE NO.	CL580
		6/7

Mar.1.2022 Copyright 2022 HIROSE ELECTRIC CO., LTD. All Rights Reserved.
In case of consideration for using Automotive equipment / device which demand high reliability, kindly contact our sales window correspondents.

[INSTRUCTIONS ON FPC LAYOUT AFTER CONNECTION]

◆Load to FPC

Be very careful not to apply any force to the FPC after inserting it.
Otherwise, the connector may become unlocked or the FPC may break.
Fix the FPC, in particular, when loads are applied to it continuously.
Design the FPC layout with care not to bend it sharply near the insertion opening.

Load: $0.01 \times n$ N MAX
(n: number of contact)

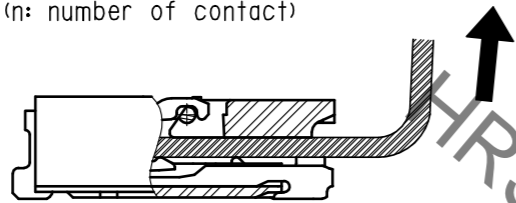

[INSTRUCTIONS ON REMOVING FPC]

◆Release the actuator to remove the FPC.

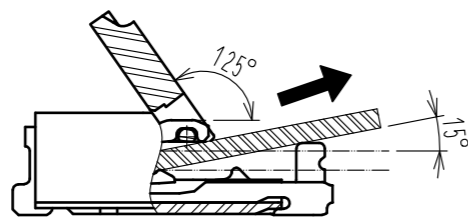

[OTHER INSTRUCTIONS]

In case a pad to support FPC is set in front of connector, that pad needs to be 0.25 MAX.

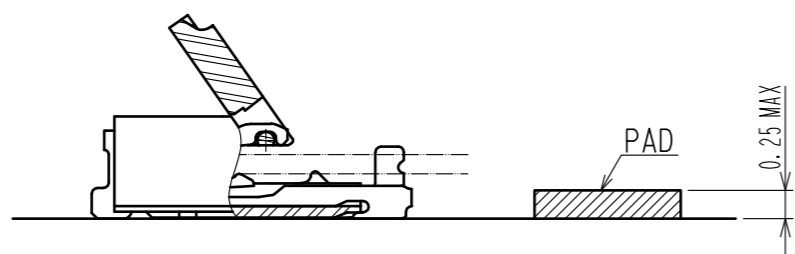

◆Instructions on Manual Soldering

Follow the instructions shown below when soldering the connector manually during repair work, etc.

1. Do not perform reflow soldering or manual soldering with the FPC inserted into the connector.
2. Do not heat the connector excessively. Be very careful not to let the soldering iron contact any parts other than connector leads. Otherwise, the connector may be deformed or melt.
3. Do not use excessive solder (or flux).

If excessive solder (or flux) is used on the terminals, solder or flux may adhere to the contacts or rotating parts of the actuator, resulting in poor contact or a rotation failure of the actuator. Supplying excessive solder to the reinforcing bracket may hinder actuator rotation, resulting in breakage of the connector.

<INSTRUCTION MANUAL 3>

HRS

DRAWING NO.	EDC-159838-00-01
PART NO.	FH43B-**S-0.2SHWC10
CODE NO.	CL580

