

Mar.1.2026 Copyright 2026 HIROSE ELECTRIC CO., LTD. All Rights Reserved.
In case of consideration for using Automotive equipment / device which demand high reliability, kindly contact our sales window correspondents.

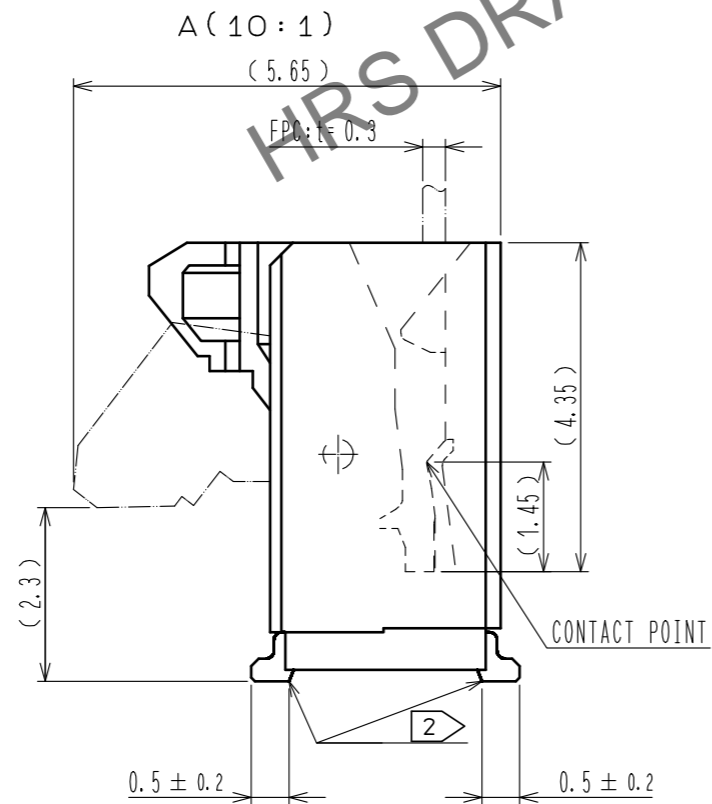
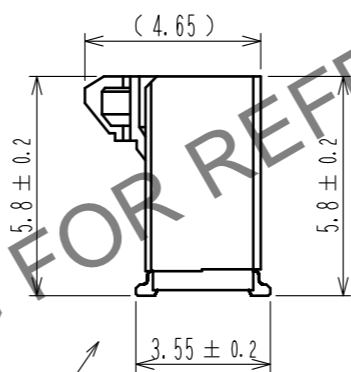
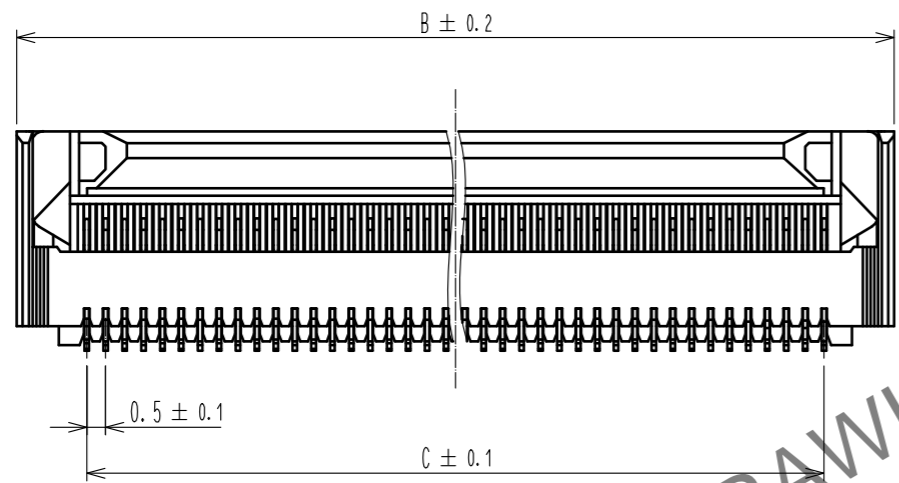
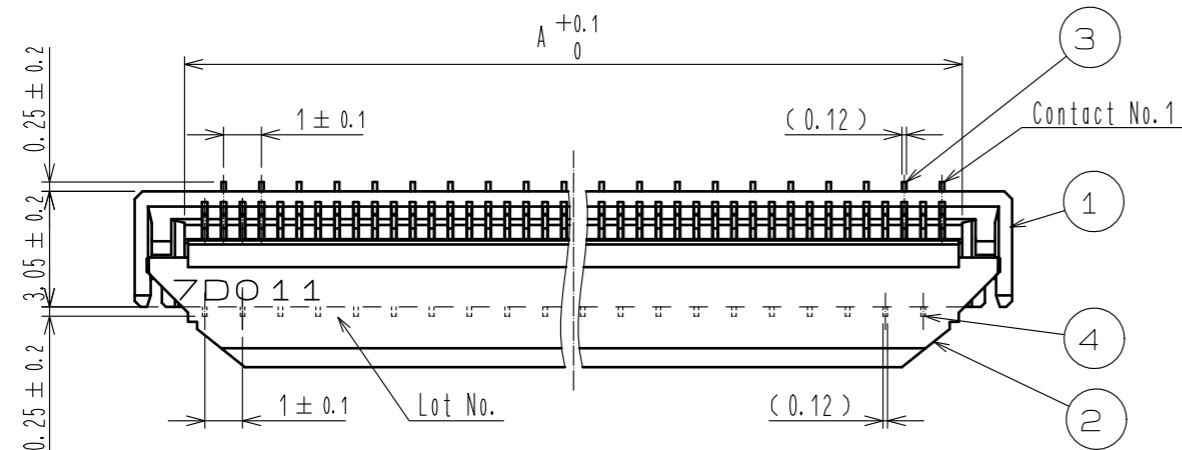

- NOTES
- The dimension in parentheses are for reference.
 - Lead CO-PLANARITY shall be 0.1 MAX.
 - See dimension table in the appendix.
 - This product satisfies halogen free requirements defined as 900ppm maximum chlorine, 900ppm maximum bromine, and 1500ppm maximum total of chlorine and bromine.
 - 'n' represents the number of contacts.

HRS DRAWING FOR REFERENCE

NO.	MATERIAL	FINISH .	REMARKS	NO.	MATERIAL	FINISH .	REMARKS
4	PHOSPHOR BRONZE	(CONTACT AREA- LEAD) GOLD PLATING 0.05µm MIN. OVER NICKEL 1µm MIN. (OTHER) NICKEL 1µm MIN.		8	(CONNECTOR)		
3	PHOSPHOR BRONZE	(CONTACT AREA- LEAD) GOLD PLATING 0.05µm MIN. OVER NICKEL 1µm MIN. (OTHER) NICKEL 1µm MIN.		7	POLYSTYRENE		
2	LCP	(BLACK)	UL94V-0	6	POLYESTER		
1	LCP	(BEIGE)	UL94V-0	5	POLYSTYRENE		

UNITS mm		SCALE 5 : 1	COUNT 4	DESCRIPTION OF REVISIONS DIS-F-00017331	DESIGNED ZHANG QIYUE	CHECKED HS. HIRAHARA	DATE 20230220
APPROVED : NF. MIYAZAKI 20141224				DRAWING NO. EDC-159298-00-05			
CHECKED : HS. SAKAMOTO 20141224				PART NO. FH40-**S-0.5SV			
DESIGNED : RT. IKEDA 20141224				CODE NO. CL580			
DRAWN : RK. OGASAWARA 20141222				1/9			

Mar.1.2026 Copyright 2026 HIROSE ELECTRIC CO., LTD. All Rights Reserved.
 In case of consideration for using Automotive equipment / device which demand high reliability, kindly contact our sales window correspondents.

RECOMMENDED PCB MOUNTING PATTERN

NUMBER OF CONTACTS: EVEN NUMBER

NUMBER OF CONTACTS: ODD NUMBER

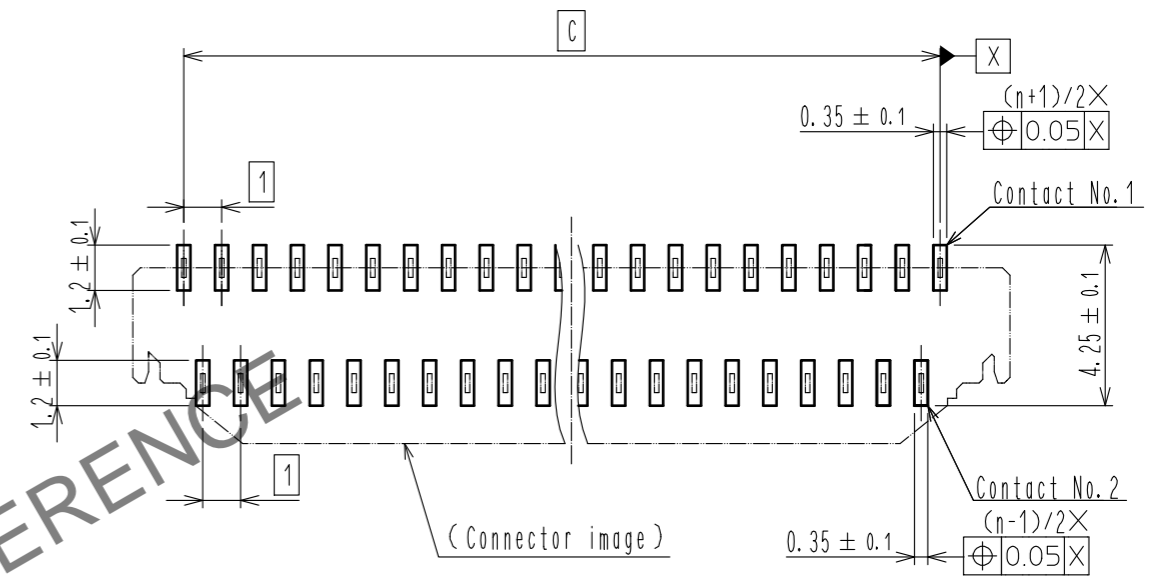
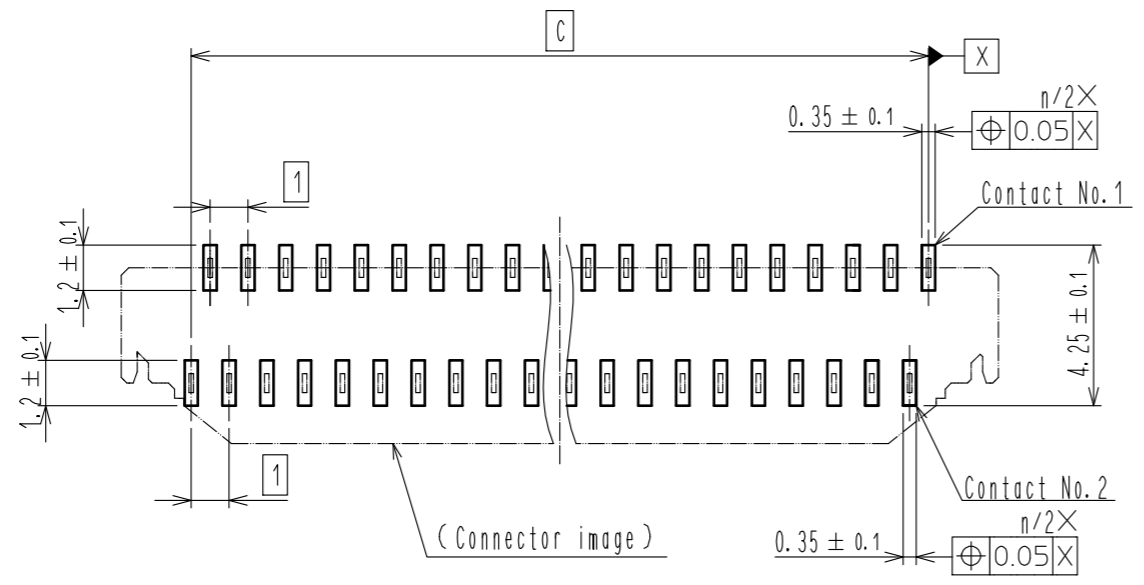

RECOMMENDED STENCIL PATTERN
 (RECOMMENDED STENCIL THICKNESS : t=0.15)

NUMBER OF CONTACTS: EVEN NUMBER

NUMBER OF CONTACTS: ODD NUMBER

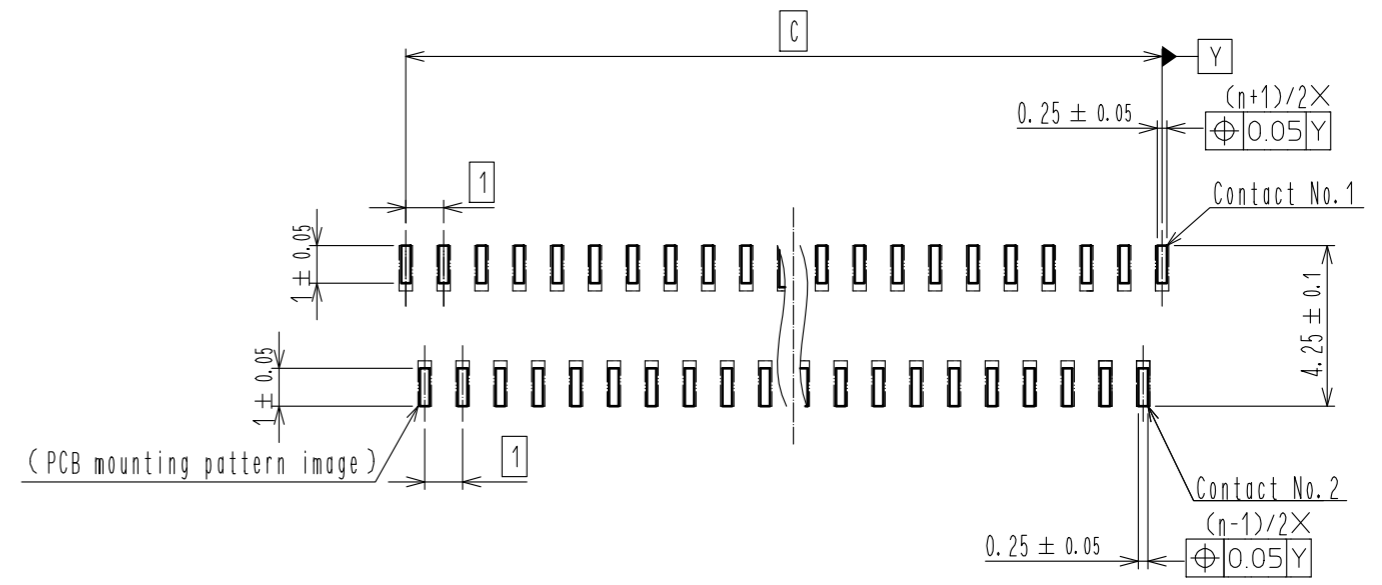
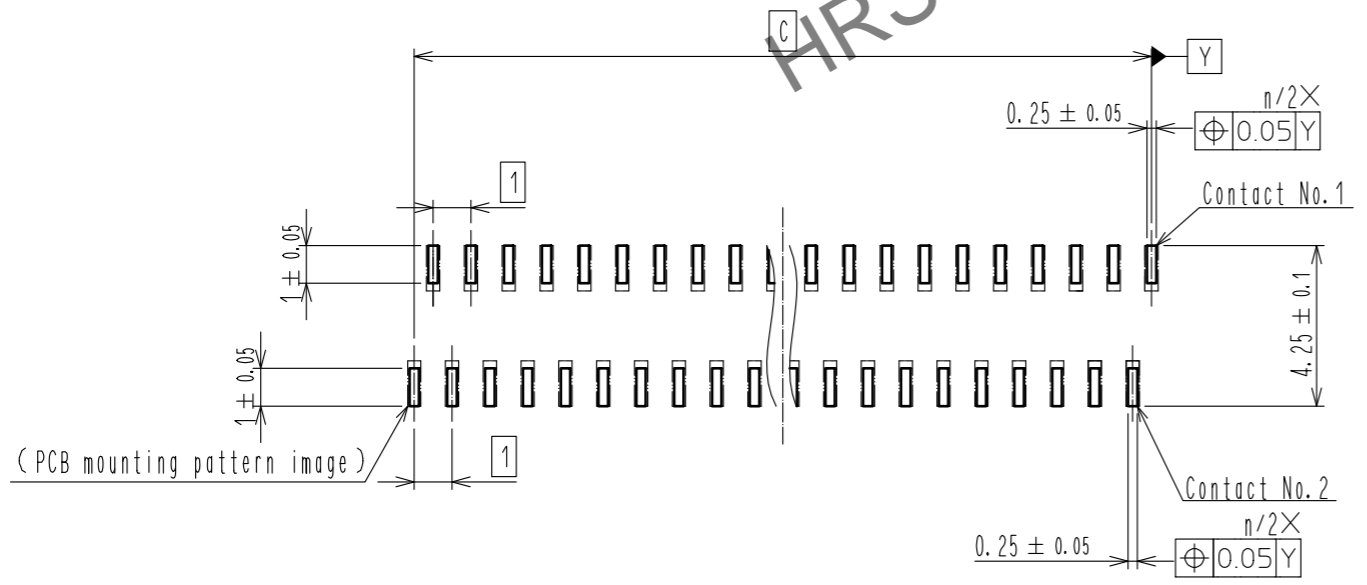

HRS	DRAWING NO.	EDC-159298-00-05
	PART NO.	FH40-**S-0.5SV
	CODE NO.	CL580
		2/9

Mar.1.2026 Copyright 2026 HIROSE ELECTRIC CO., LTD. All Rights Reserved.
 In case of consideration for using Automotive equipment / device which demand high reliability, kindly contact our sales window correspondents.

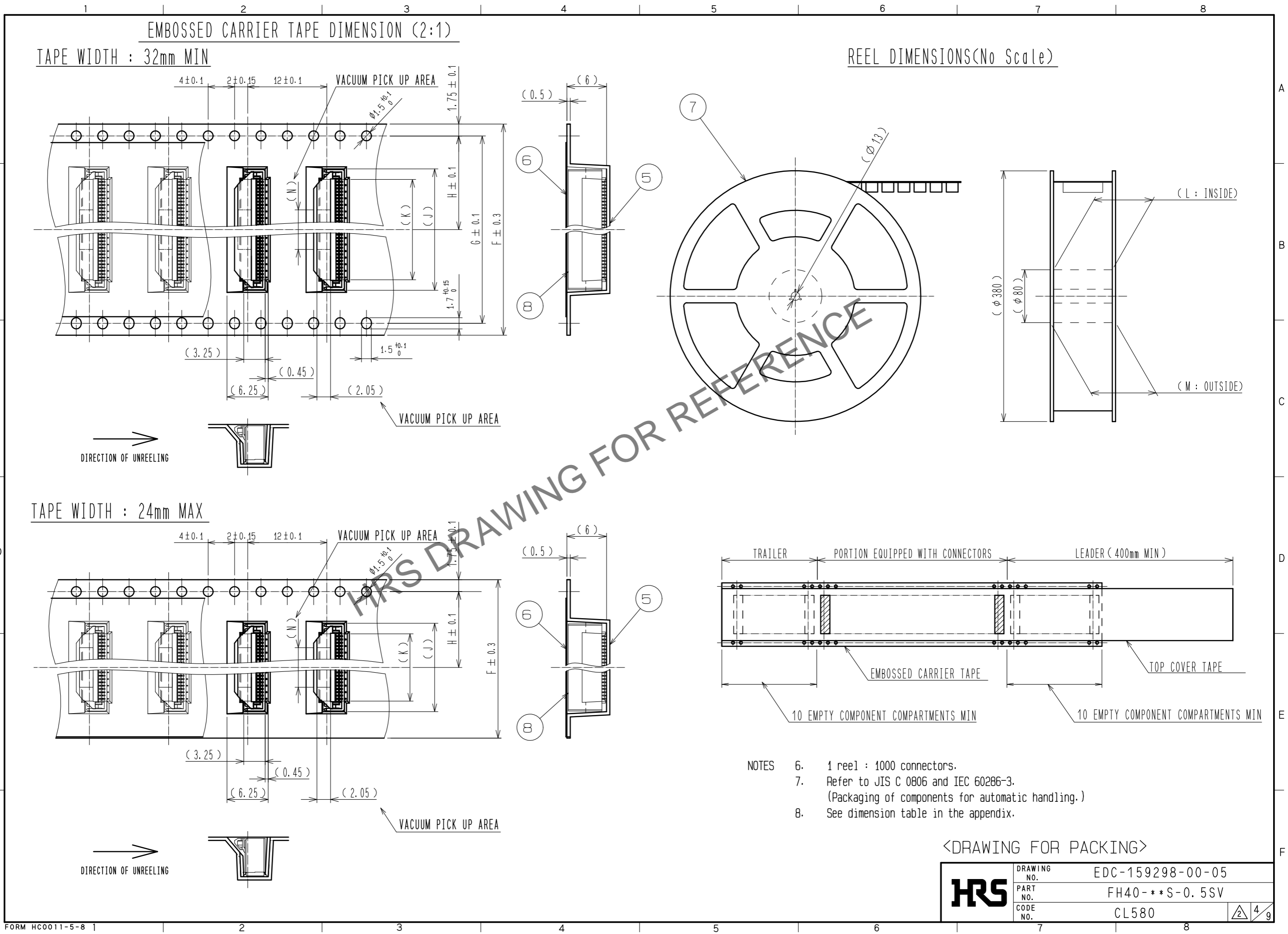

- NOTES
- 6. 1 reel : 1000 connectors.
 - 7. Refer to JIS C 0806 and IEC 60286-3.
(Packaging of components for automatic handling.)
 - 8. See dimension table in the appendix.

<DRAWING FOR PACKING>

HRS	DRAWING NO.	EDC-159298-00-05	4/9
	PART NO.	FH40-**S-0.5SV	
	CODE NO.	CL580	

Mar.1.2026 Copyright 2026 HIROSE ELECTRIC CO., LTD. All Rights Reserved.
 In case of consideration for using Automotive equipment / device which demand high reliability, kindly contact our sales window correspondents.

PART NO.	CODE NO.	NUMBER OF CONTACT	DIMENSION OF CONNECTOR, PCB MOUNTING PATTERN, STENCIL PATTERN AND FFC/FPC					DIMENSION OF DRAWING FOR PACKING							
			A	B	C	D	E	F	G	H	J	K	L	M	N
FH40-10S-0.5SV	CL580-2104-6	10	5.57	8.2	4.5	5.5	7.1	16	—	7.5	8.4	5.2	17.4	21.4	3.5
FH40-20S-0.5SV	CL580-2105-9	20	10.57	13.2	9.5	10.5	12.1	24	—	11.5	13.4	10.2	25.4	29.4	6
FH40-24S-0.5SV	CL580-2106-1	24	12.57	15.2	11.5	12.5	14.1	24	—	11.5	15.4	12.2	25.4	29.4	6
FH40-30S-0.5SV	CL580-2108-7	30	15.57	18.2	14.5	15.5	17.1	32	28.4	14.2	18.4	15.2	33.4	37.4	6
FH40-40S-0.5SV	CL580-2107-4	40	20.57	23.2	19.5	20.5	22.1	44	40.4	20.2	23.4	20.2	45.4	49.4	6
FH40-45S-0.5SV	CL580-2101-8	45	23.07	25.7	22	23	24.6	44	40.4	20.2	25.9	22.7	45.4	49.4	6
FH40-50S-0.5SV	CL580-2100-5	50	25.57	28.2	24.5	25.5	27.1	44	40.4	20.2	28.4	25.2	45.4	49.4	6
FH40-60S-0.5SV	CL580-2109-0	60	30.57	33.2	29.5	30.5	32.1	56	52.4	26.2	33.4	30.2	57.4	61.4	6
FH40-64S-0.5SV	CL580-2102-0	64	32.57	35.2	31.5	32.5	34.1	56	52.4	26.2	35.4	32.2	57.4	61.4	6
FH40-80S-0.5SV	CL580-2103-3	80	40.57	43.2	39.5	40.5	42.1	56	52.4	26.2	43.4	40.2	57.4	61.4	8

HRS DRAWING FOR REFERENCE

HRS	DRAWING NO.	EDC-159298-00-05	
	PART NO.	FH40-**S-0.5SV	
	CODE NO.	CL580	2/5/9

Mar.1.2026 Copyright 2026 HIROSE ELECTRIC CO., LTD. All Rights Reserved.
 In case of consideration for using Automotive equipment / device which demand high reliability, kindly contact our sales window correspondents.

This connector requires delicate and careful handling.
 To prevent connector/FPC/FFC breakage and contact failure
 (mating failure, FPC/FFC pattern breakage, etc),
 read through the instructions shown below and handle the connector properly.
 This instruction manual is applicable to usage with FPC/FFC.

[Connector part nomenclature]

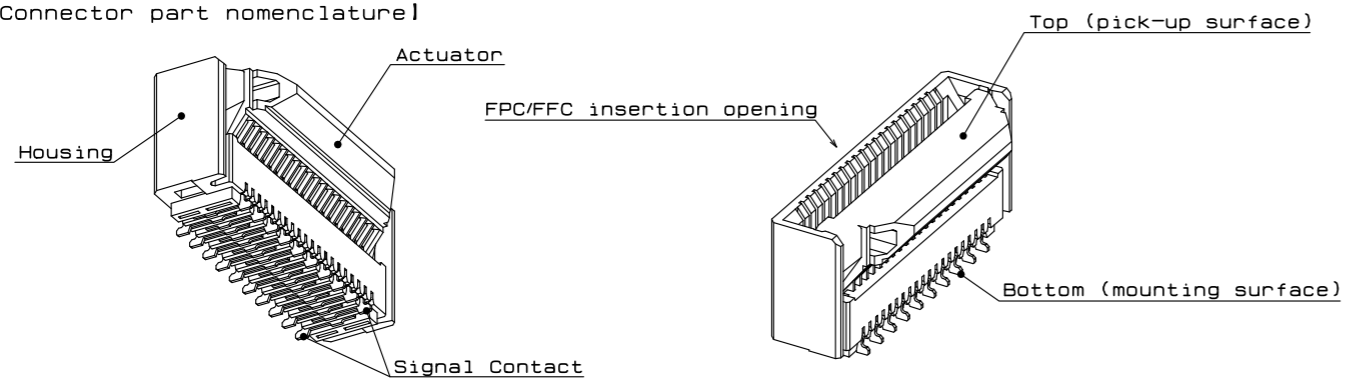

[Operation and precautions]

1. Initial condition

The product is delivered with the actuator closed.
 It is not necessary to open the actuator before FPC/FFC insertion.

[Caution]

- Do not open the actuator when the FPC/FFC is not inserted(Example 1).
- Do not insert FPC/FFC or operate actuator before mounting(Example 1).

Example 1)

X NG

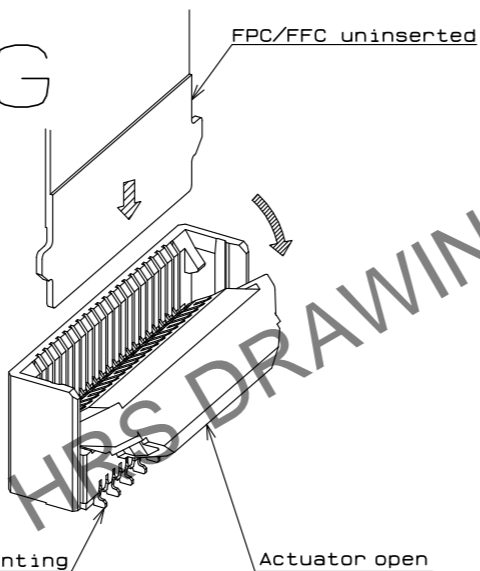

- When delivered -

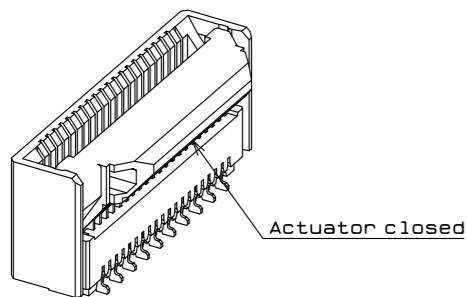

Actuator closed

2. How to insert FPC/FFC

Insert the FPC/FFC into the connector along the direction vertical to the PCB board
 while the actuator is closed(Example 2).
 Make sure the front end of the FPC/FFC reach the very end of the FPC/FFC insertion opening.

[Caution]

- Make sure the actuator is closed when inserting the FPC/FFC.
 Do not insert the FPC/FFC when the actuator is open(Example 3).
- The structure prevents the FPC/FFC from being inserted when the actuator is open.
 forcibly inserting the FPC/FFC may cause damage.
- Do not press the actuator while inserting the FPC/FFC(Example 4).
- Insert the FPC/FFC with the pattern side opposite to the actuator operation part(Example 5).
- Position both sides of the FPC/FFC in a vertical position
 to the insertion opening, and insert it straight. (Example 6).
- Insert the FPC/FFC so that it is not oblique to the insertion direction(Example 7).
- When inserting the FPC/FFC, do not twist it vertically, horizontally, or diagonally(Example 8).
- Do not touch actuator with fingers when inserting FPC/FFC,
 actuator may be opened in the process(Example 9).

Example 2)

O OK

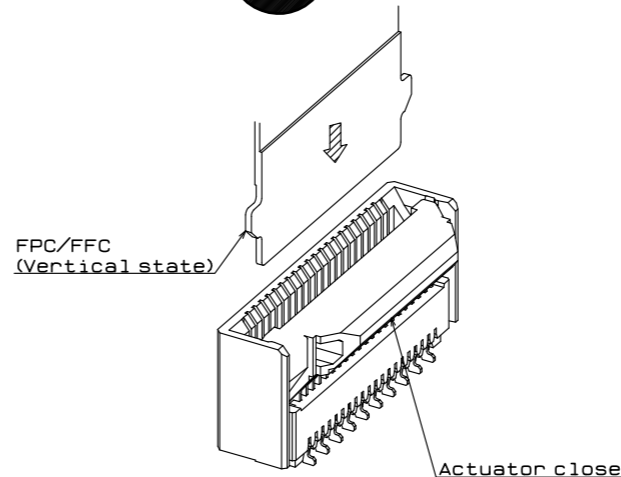

Example 3)

X NG

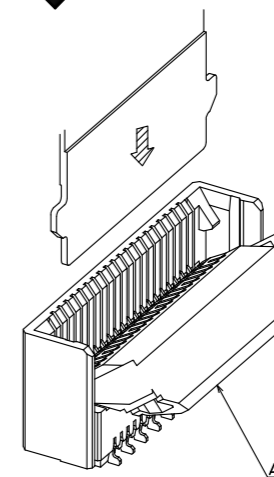

Example 4)

X NG

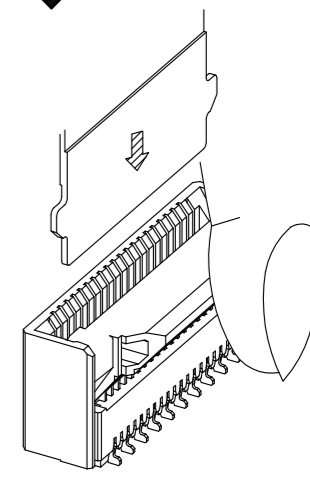

Example 5)

O OK

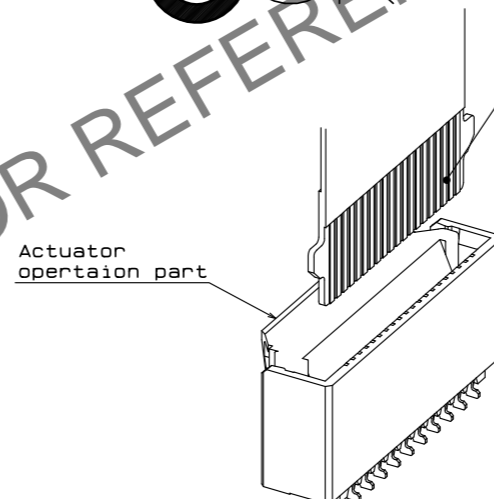

Example 6)

O OK

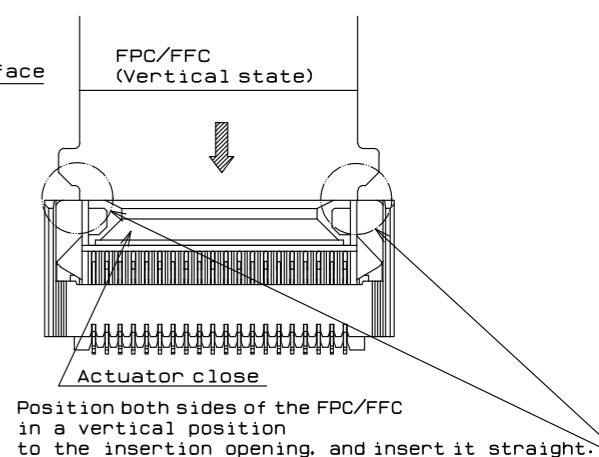

Example 7)

X NG

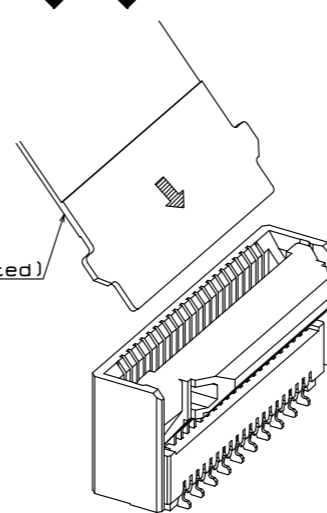

Example 8)

X NG

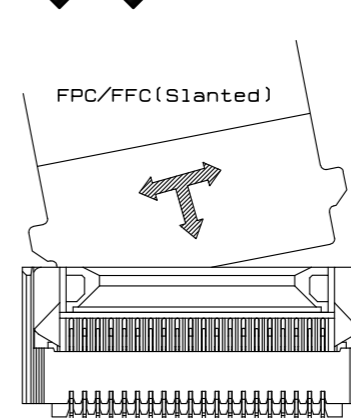

Example 9)

X NG

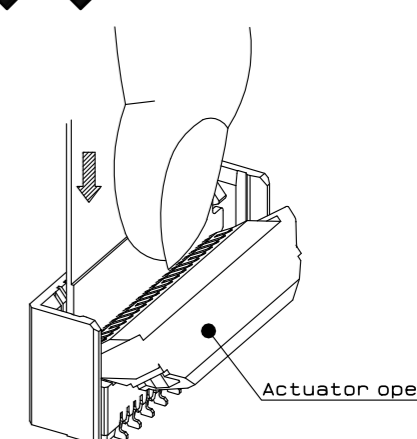

△ <Instruction manual(1)>

HRS	DRAWING NO.	EDC-159298-00-05
	PART NO.	FH40-**S-0.5SV
	CODE NO.	CL580
		△ 6/9

Mar.1.2026 Copyright 2026 HIROSE ELECTRIC CO., LTD. All Rights Reserved.
In case of consideration for using Automotive equipment / device which demand high reliability, kindly contact our sales window correspondents.

3. FPC insertion check
 Make sure that the FPC/FFC tabs are located in proper position after FPC insertion (Example 10).
 (The FPC/FFC position is localized by the positioning guide part of the housing.)

[Caution]
 - Do not insert the FPC/FFC at an angle and/or stop it before insertion is completed (Example 11, 12).

Example 10)

OK

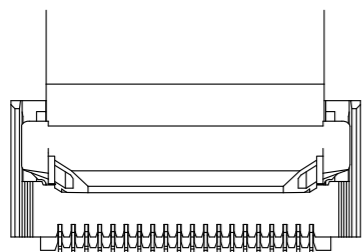

FPC/FFC is completely inserted to the end.

Example 11)

NG

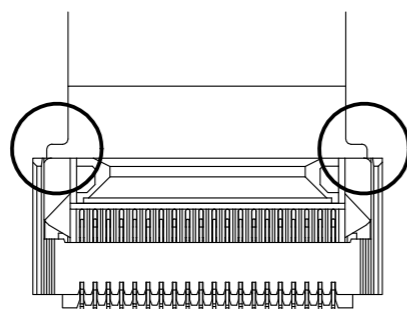

Insertion of FPC/FFC is shallow and not fully inserted to the end.

Example 12)

NG

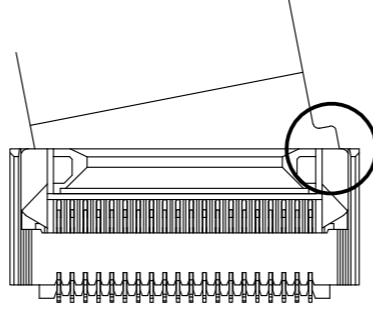

FPC/FFC is inserted obliquely and not fully inserted to the end.

4. Use of the actuator (open/close)
 Slowly flip down the actuator to lock the FPC/FFC (Example 13).
 Slowly flip up the actuator to release the lock (Example 14).

[Caution]
 - To open/close the actuator, operate at the center of the actuator (Example 15).
 - To open/close the actuator, do not operate the actuator at one end only (Example 16).
 - The actuator rotates up to 90 degree.
 Do not rotate the actuator more than 90 degree (Example 17).
 - Do not lift or pull the actuator (Example 18).
 - Operate the actuator by hand only, and do not operate it with sharp jigs such as tweezers (Example 19).
 - Do not apply excess force to the actuator during the operation (Example 20).

Example 13)

OK

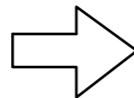
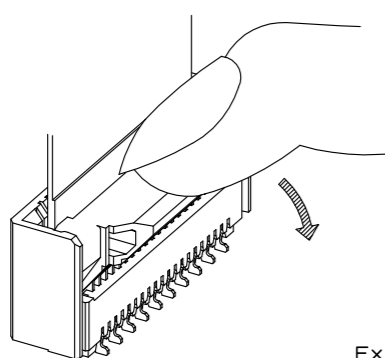

Example 14)

OK

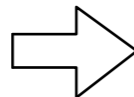
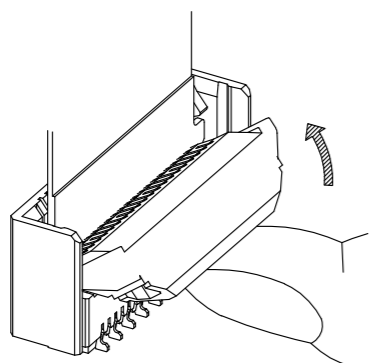

Example 15)

OK

Operate the actuator at the center

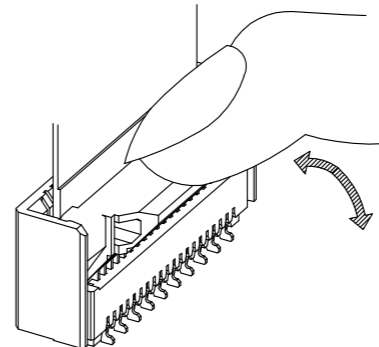

Example 16)

NG

Do not operate the actuator at one end only

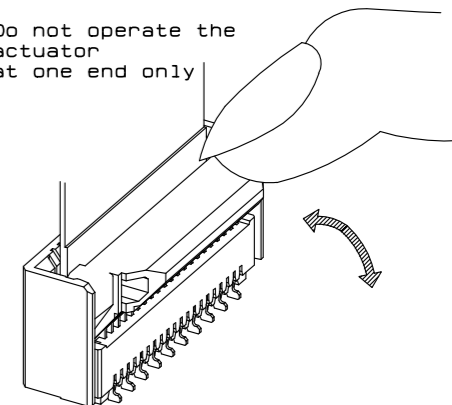

Example 17)

NG

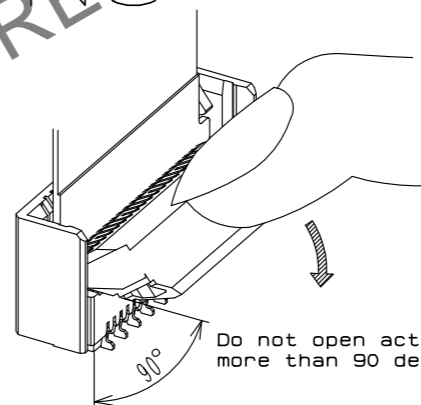

Do not open actuator more than 90 degree.

Example 18)

NG

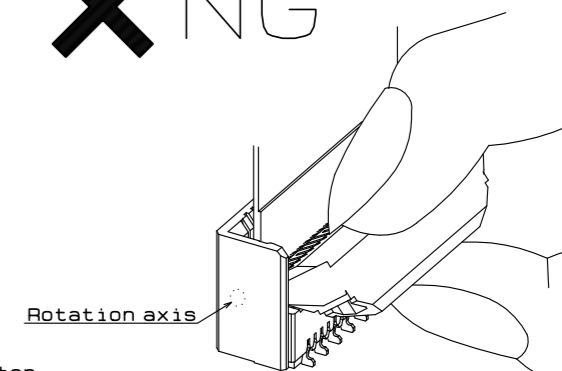

Excess stress applied on the rotation axis lead to damage to the axis.

Example 19)

NG

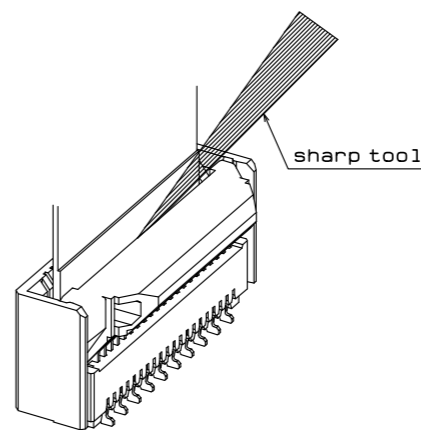

sharp tool

Example 20)

NG

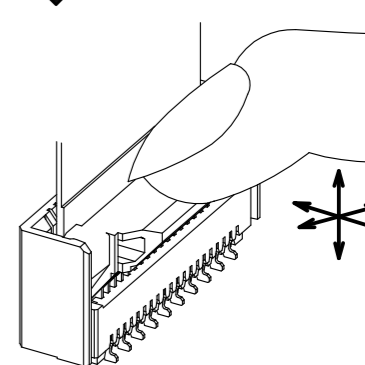

Do not apply excess force to the actuator during the operation.

△ <Instruction manual(2)>

HRS	DRAWING NO.	EDC-159298-00-05	△ 7/9
	PART NO.	FH40-**S-0.5SV	
	CODE NO.	CL580	

Mar.1.2026 Copyright 2026 HIROSE ELECTRIC CO., LTD. All Rights Reserved.
In case of consideration for using Automotive equipment / device which demand high reliability, kindly contact our sales window correspondents.

5. How to remove FPC

After flip up the actuator to the unlocked position, withdraw the FPC/FFC vertically(Example 21).

[Caution]

- Do not attempt to pull the FPC/FFC without unlocking the actuator(Example 22).
- After the FPC/FFC is forcibly pulled out, retention force of FPC/FFC may decrease.
- This connector has an FPC retention mechanism using an actuator. When removing the FPC, do not apply a load in any direction other than the vertical direction of the PCB board(Example 23).

[Precautions for component layout]

While the FPC/FFC is under tension due to the connecting configuration, extra stress may be applied to the connector. As a result, conduction failure may occur due to the extra stress. In order to prevent such kind of conduction failure, please read through the following parts before making circuits/mechanism design.

[Caution]

- Avoid applying forces to/pulling the FPC/FFC along/perpendicular to the direction of FPC/FFC insertion. (example 26)
- Avoid pushing/pulling the FPC/FFC upwards/downwards.
- If the FPC/FFC has to be curled/bended in your cabling design, please keep enough degree of freedom in your design to keep the FPC/FFC tension free. In this regard, the stiffener should be parallel to the PCB. (example 24)
- If the FPC/FFC has to be curled/bended in your cabling design, do not curl/bend the FPC/FFC area near the connector. This may lead to conduction failure or FPC/FFC breakage. (example 25)
- It is recommended to keep the FPC/FFC fixed to avoid applying stress through the FPC/FFC to the connector.
- Do not mount other components underneath the FPC/FFC stiffener which may interfere with the connection. (example 27)
- Follow the recommended FPC/FFC design. Please consult with the FPC/FFC manufacturer about FPC/FFC bending performance and wire breakage strength while making design.
- Keep sufficient operating space for FPC/FFC insertion during layout design in order to avoid incorrect FPC/FFC insertion. Please keep enough FPC/FFC length and component layout space for assembly during design process. FPC/FFC with too short length may make the assembly difficult.
- Keep enough space for the rotation of the actuator during PCB and component layout design.
- Please consult with our sales representative if you are using FPC/FFC with different configuration from our recommendation.

Example 21)

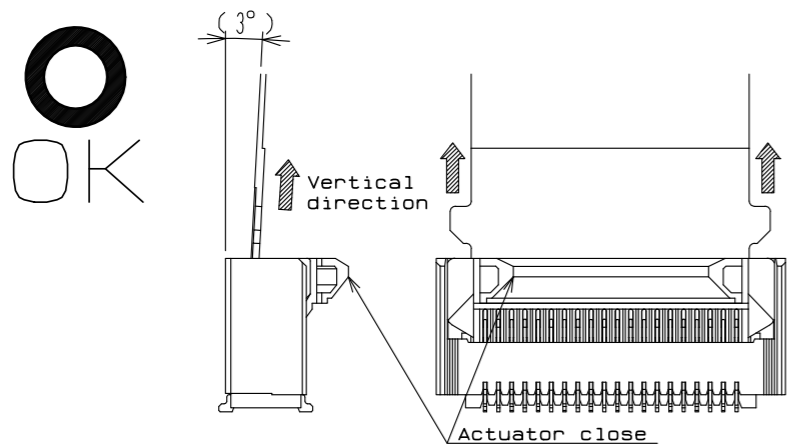

Example 22)

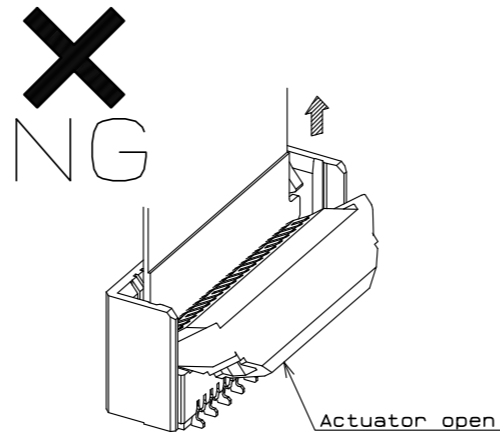

Example 23)

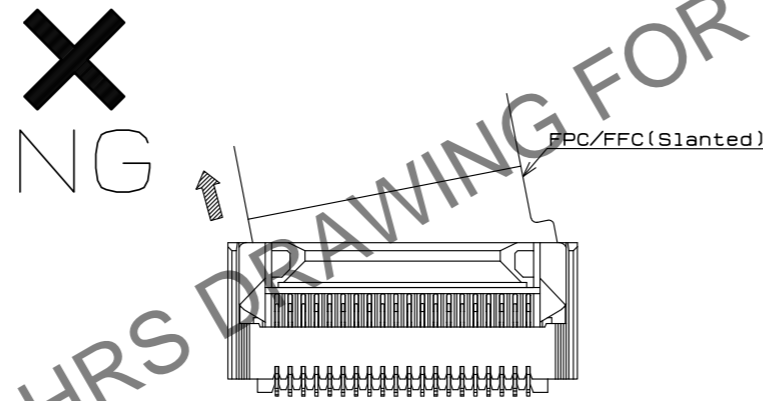
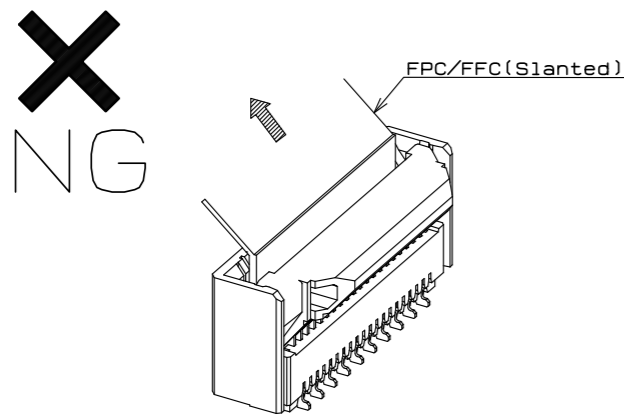

Example 24)

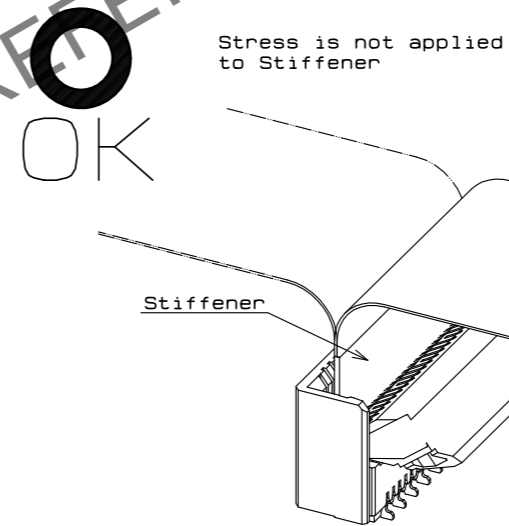

Example 25)

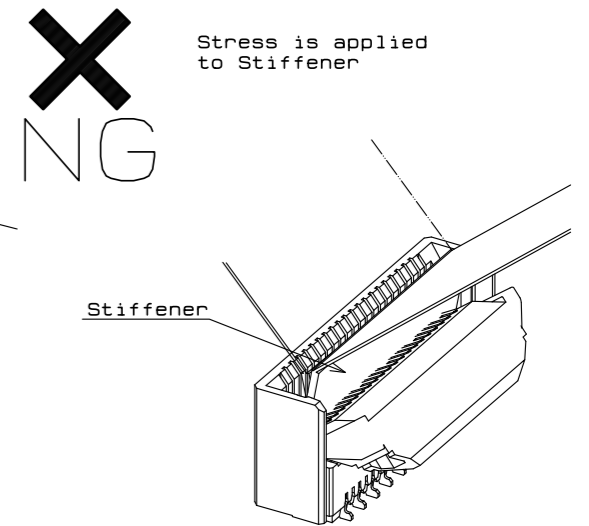

Example 26)

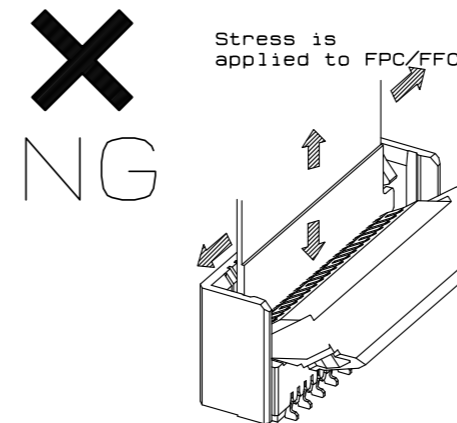

Example 27)

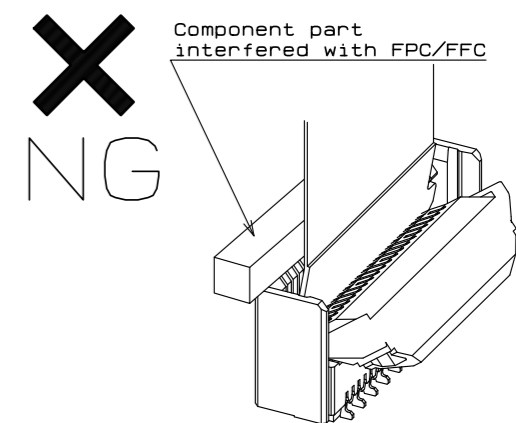

△ <Instruction manual(3)>

HRS	DRAWING NO.	EDC-159298-00-05
	PART NO.	FH40-**S-0.5SV
	CODE NO.	CL580
		△ 8/9

Mar.1.2026 Copyright 2026 HIROSE ELECTRIC CO., LTD. All Rights Reserved.
In case of consideration for using Automotive equipment / device which demand high reliability, kindly contact our sales window correspondents.

[Instructions for mounting on the PCB]

Follow the instructions shown below when mounting on the PCB.

[Caution]

- Refer to recommended layouts on page 1 for PCB and stencil pattern.
- Using either narrower land pattern or wider stencil pattern than recommendation may end up with excessive amount of solder/flux climbing on contact. Please inspect the size of solder fillet and flux climbing height of the mounted connector while using different land/stencil pattern from our recommendation.
- Clearance between the mounting surface of the connector contact lead and the bottom of the housing is very small. Solder resist/silk screening applied underneath the connector may interfere with the connector. This may lead to soldering defect/insufficient fillet formation. Please verify your solder resist/silk screening design carefully before implementing the design.
- Apply reflow temperature profile within the specified conditions. For specific applications, the recommended temperature may vary depending on type/ volume/thickness of solder paste and size/thickness of PCB. Please consult with your solder paste and equipment manufacturer for specific recommendations.
- Please try to minimize the warpage of the PCB. Soldering failure could still occur due to the PCB warpage even if the coplanarity of the connector is under 0.1mm.
- If the connector is mounting on FPC/FFC, please make sure to put a stiffener on the backside of the FPC/FFC. Recommended stiffener: Glass epoxy material with thickness of 0.3 mm MIN.
- Do not apply 1 N or greater external force on the connector when unreeling or handling the connector before mounting. Excessive mechanical stress may damage the connector before mounting.

[Instructions for PCB handling after mounting the connector]

Follow the instructions shown below when mounting on the PCB.

[Caution]

- Splitting a large PCB into several pieces
 - Installing mounting screw on PCB
- During the assembly processes described above, care shall be taken so as not to give any stresses of deflection or twisting to the PCB. Stresses applied on PCB may damage the connector as well
- The warpage of a 100 mm wide PCB should remain within 0.5 mm .(example 27)
 - The warpage of PCB may apply excessive stress on the connector and damage the connector.
 - Please perform conduction check with caution. Conductivity probe may damage the connector contacts.
 - Attachment of foreign particles with the connector contact may lead to conduction failure. In this particular case, the conduction failure may be fixed by re-inserting the FPC/FFC.

Example 27)

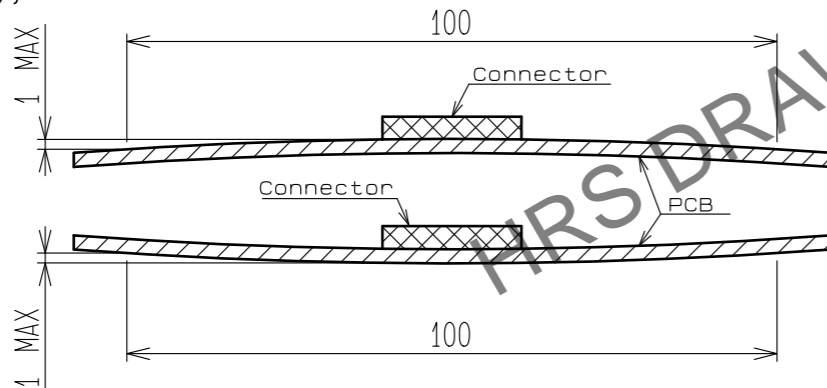

[Instructions on manual soldering]

Follow the instructions shown below when soldering the connector manually during repair work, etc.

[Caution]

- Do not perform manual soldering with the FPC inserted into the connector.
 - Do not heat the connector excessively. Be very careful not to let the soldering iron contact any parts other than connector leads. Otherwise, the connector may be deformed or melt.
 - Do not supply excessive solder (or flux).
- If excessive solder (or flux) is supplied on the contact lead, solder or flux may adhere to the contact point, resulting in contact failure.

[Recommended reflow temperature profile]

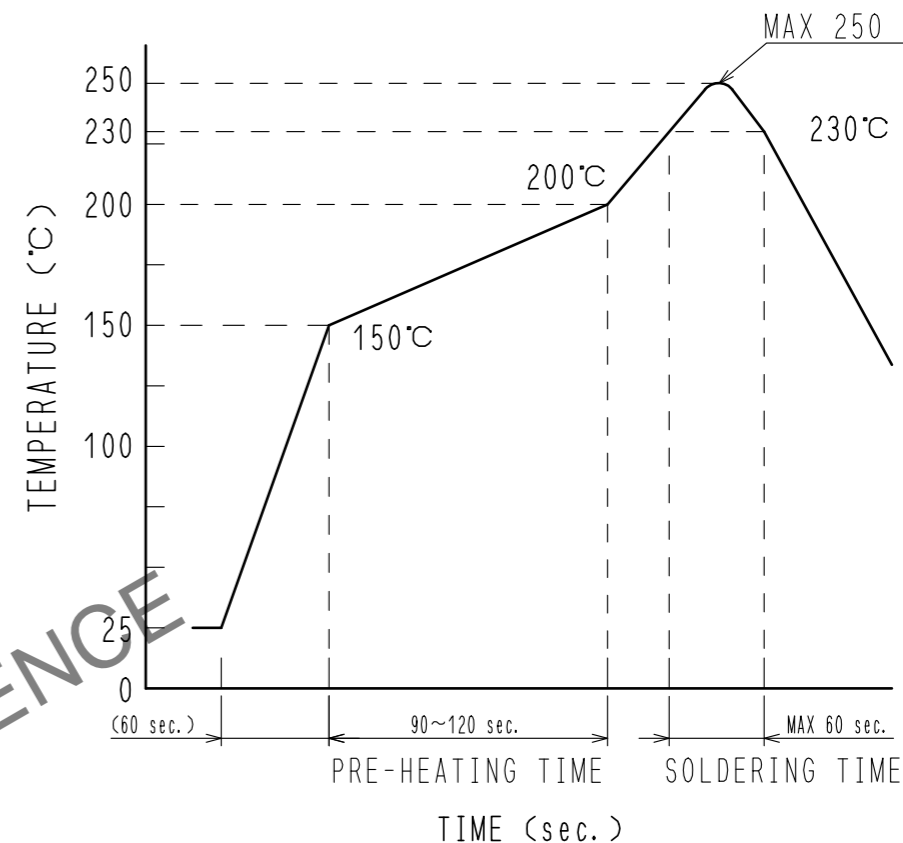

Reflow method: IR reflow
 Number of reflow cycles: 2 cycles MAX.
 1) Reflow time
 Duration above 230°C: 60 sec MAX.
 (Peak temperature: 250°C MAX)
 2) Pre-heat time
 Pre-heat temperature (MIN): 150°C
 Pre-heat temperature (MAX): 200°C
 Pre-heat time: 90~120 sec.

△ <Instruction manual(4)>

HRS	DRAWING NO.	EDC-159298-00-05
	PART NO.	FH40-***S-0.5SV
	CODE NO.	CL580

△ 9/9