

REV	CHANGE	DATE	DRN	CHK
	Drawn	12/30/2016	SJ	T

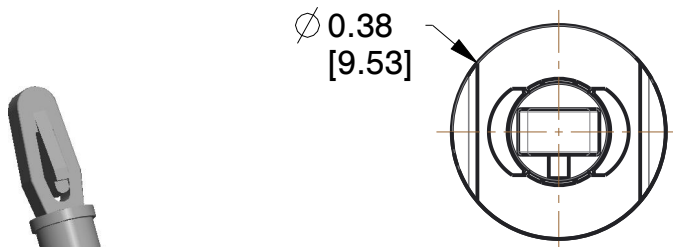

ϕ 0.38
[9.53]

To Snap-fit in a 0.125 (3.18)
 \pm 0.003 (0.08) dia. hole in a
1/16" (1.60) nomial thk.
board/ panel

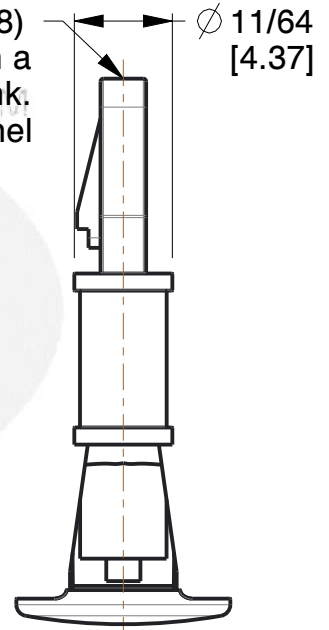

ϕ 11/64
[4.37]

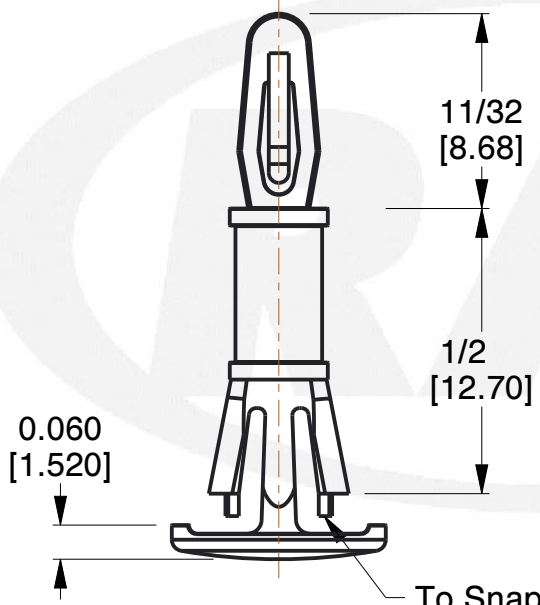

0.060
[1.520]

To Snap-Lock in a 0.187 (4.76)
 \pm 0.003 (0.08) dia. hole in a
0.059 (1.50) to 0.063 (1.60) thk.
panel/chassis

NOTES:

1. Material : Nylon
2. Finish :
3. ASME Y14.5M - 2009
4. All Drawing Dimensions are in Inches [mm]
5. Unless otherwise specified; Edge Breaks, Radii or Countersinks 0.005-0.015

COMPONENT	CB SUPPORTS
30183-N REVERSE LOCKING	SCALE
	2.97
	SHEET
	1 of 1



95 Silvermine Rd., Seymour CT 06483
Tel: 203-888-2133, Fax: 203-888-9860

This Drawing is the Property of RAF.
It contains confidential, proprietary
information that is RAF property. Do
not disclose to or duplicate for others
except as authorized by RAF.

TOLERANCES
ALL DIMENSIONS ARE INCHES
(UNLESS OTHERWISE SPECIFIED)
METALLIC
LENGTHS < 6 INCHES \pm 0.005
LENGTH > 6 INCHES \pm 0.010
DIAMETERS: \pm 0.005
NON-METALLIC
LENGTH: \pm 0.010 DIAMETERS: \pm 0.010
INTERNAL THREADS:
MINIMUM THREAD DEPTH